



KB Killbros Grain Carts

Model 1150 & 1160

Model 1150 Beginning With Serial Number D10000000 & UP

Model 1160 Beginning With Serial Number D10000000 & UP

Part No. 252318

Foreword

Your new GRAIN CART is designed and manufactured to give you years of dependable service. To keep it running efficiently, read the instructions in this operator's manual.

This manual covers operation, service, assembly, and parts for your GRAIN CART. Read and study manual completely before attempting to operate this implement. Take this manual to the field for handy reference when operating, adjusting, or servicing your machine.

“Right-Hand” and “Left-Hand” side of the machine are determined by standing behind the implement and facing in the direction of forward travel.



This symbol identifies important safety messages. When you see it, read the message that follows and be alert to the possibility of personal injury.

Remember, safety instructions stated in this manual are for your protection. Read them carefully and follow them closely when working around or using this machine.

IMPORTANT

- *The information, specifications, and illustrations in the manual are on the basis of information available at the time it was written. Due to continuing improvements in the design and manufacture of Unverferth products, all specifications and information contained herein are subject to change without notice.*

Product Information

Please fill out and retain this portion for your records. All products manufactured by Unverferth Mfg. Co., Inc. are warranted to be free from material and workmanship defects for one full year from time of consumer delivery. Your local dealer will gladly assist you with any warranty questions.

The serial number plate is located as shown in Fig. 1.

Product _____

Serial Number _____

Date of Purchase _____

Dealer _____

City _____ State _____ Zip _____

Please supply this information when you have questions or when ordering repair or replacement parts. Your dealer needs this information to give you prompt, efficient service.

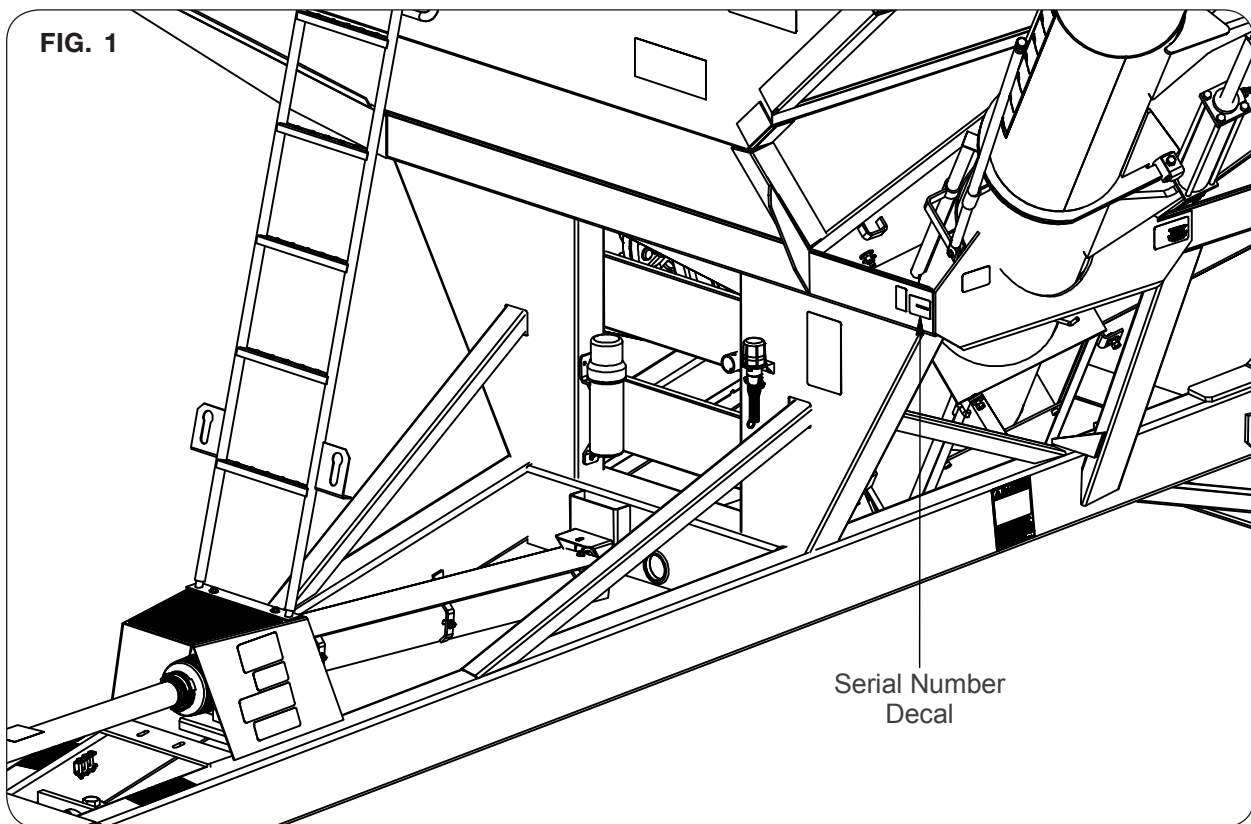

Table of Contents

SECTION I
Safety

General Hazard Information	1-2
Safety Decals	1-3
Follow Safety Instructions	1-4
Before Servicing	1-4
Before Operating	1-4
During Operation	1-5
Before Transporting	1-5
During Transport	1-5
Driveline Safety	1-6
Pressurized Oil	1-7
Preparing For Emergencies	1-8
Wearing Protective Equipment	1-8

Table of Contents

SECTION II
Set Up

Set Up Checklist..... 2-2

Basic Cart Set Up

- Folding Side Extension Set Up 2-3
- Ladder..... 2-3
- Jack..... 2-3
- Standard Chute Installation 2-3
- Optional Extension Chute Installation..... 2-4
- Driveline Storage..... 2-4
- Wheel/Tire Set Up..... 2-5

Table of Contents

SECTION III
Operation

Preparing Tractor.....	3-2
Preparing Cart	
Inspection.....	3-3
Lubrication.....	3-3
Hitching To Tractor	
Drawbar Connection.....	3-4
Jack.....	3-4
Hydraulic Connections.....	3-5
Electrical Connections.....	3-6
Towing.....	3-8
Auger Operation.....	3-8
PTO-Driven Auger.....	3-9

Table of Contents

SECTION IV
Maintenance

Lubrication..... 4-2
Gearbox Lubrication 4-3
Seasonal Storage 4-3
Hydraulic System 4-4
 Purge Hydraulic System 4-4
 Relieving Hydraulic Pressure 4-5
Verify Telescoping PTO Shaft Length 4-6
Auger Driveline
 Bearings..... 4-8
 Driveline Replacement 4-8
 Gearbox..... 4-11
 PTO Clutch Shear Bolt..... 4-11
PTO Shaft & Clutch..... 4-12
PTO Quick Disconnect Pin..... 4-14
Auger System
 Lower Auger 4-15
 Upper Auger..... 4-16
Wheel Torque Chart & Tire Specifications 4-18
 Tire Pressure 4-19
 Tire Warranty 4-21
Torque Chart 4-22
Hydraulic Fittings 4-23

Table of Contents

SECTION V
Parts

Final Assembly	5-2
Hitch	5-4
Axle	5-5
Hub - Model 1150	5-6
Hub - Model 1160	5-7
Wheels & Tires - Model 1150	5-8
Wheels & Tires - Model 1160	5-9
Decals	5-10
Sideboards	5-12
Electrical	5-14
Auger & Hydraulics	5-16
Upper Auger	5-18
Lower Auger & Driveline	5-19
Directional Downspout Control Kit #27122B (Optional)	5-20
Auger Chutes	5-22
Auger Cylinder	5-23
Flow Control Door Cylinder	5-23
PTO Assembly	5-24
PTO Clutch	5-25
50° Gearbox	5-26
Driveline U-Joint Assembly	5-27

PLEASE REFER TO THE APPROPRIATE ACCESSORY MANUAL IF EQUIPPED:
SCALES
HYDRAULIC DRIVE
WEATHER GUARD TARP

SECTION I

Safety

General Hazard Information	1-2
Safety Decals	1-3
Follow Safety Instructions	1-4
Before Servicing	1-4
Before Operating	1-4
During Operation	1-5
Before Transporting	1-5
During Transport	1-5
Driveline Safety	1-6
Pressurized Oil	1-7
Preparing For Emergencies	1-8
Wearing Protective Equipment	1-8

General Hazard Information

No accident-prevention program can be successful without the wholehearted cooperation of the person who is directly responsible for the operation of the equipment.

A large number of accidents can be prevented only by the operator anticipating the result before the accident is caused and doing something about it. No power-driven equipment, whether it be transportation or processing, whether it be on the highway, in the field, or in the industrial plant, can be safer than the person who is at the controls. If accidents are to be prevented--and they can be prevented--it will be done by the operators who accept the full measure of their responsibility.

It is true that the designer, the manufacturer, and the safety engineer can help; and they will help, but their combined efforts can be wiped out by a single careless act of the operator.

It is said that, "the best kind of a safety device is a careful operator." We, at Unverferth Mfg. Co., Inc. ask that you be that kind of operator.



REMEMBER:
THINK SAFETY
A CAREFUL OPERATOR IS THE
BEST INSURANCE AGAINST AN
ACCIDENT!

SIGNAL WORDS

 **DANGER**

INDICATES AN EXTREMELY HAZARDOUS SITUATION OR ACTION THAT WILL RESULT IN SERIOUS INJURY OR DEATH.

 **WARNING**

INDICATES A HAZARDOUS SITUATION OR ACTION THAT COULD RESULT IN SERIOUS INJURY OR DEATH.

 **CAUTION**

INDICATES AN UNSAFE SITUATION OR ACTION THAT MAY RESULT IN PERSONAL INJURY.

IMPORTANT

Is used for instruction on operating, adjusting, or servicing a machine.

Safety Decals

⚠️ WARNING

- REPLACE LOST, DAMAGED, PAINTED, OR UNREADABLE DECALS IMMEDIATELY. IF PARTS THAT HAVE DECALS ARE REPLACED, ALSO MAKE SURE TO INSTALL NEW DECALS. THESE DECALS INFORM AND REMIND THE OPERATOR WITH OPERATIONAL INFORMATION AND SAFETY MESSAGES.

Part No. 9003475



Part No. 9003477

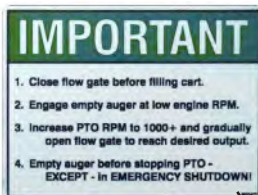

Part No. 9003474



Part No. 9003476



Part No. 9008151



Part No. 95839



Part No. 95046



Part No. 97961



Part No. 94094

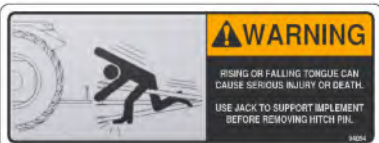

Part No. 97575

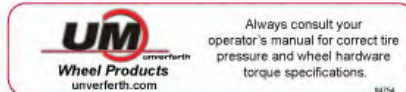

Part No. 94754

Part No. 95046







Part No. 9003475



Part No. 95445



Follow Safety Instructions

- Read and understand this operator's manual before operating. 
- All machinery should be operated only by trained and authorized personnel.
- To prevent machine damage, use only attachments approved by the manufacturer.
- Always shut towing vehicle engine and hydraulic power unit engine off & remove key before servicing the implement. 
- Avoid personal attire such as loose fitting clothing, shoestrings, drawstrings, pants cuffs, long hair, etc. that may become entangled in moving parts.
- Do not allow anyone to ride on the equipment. Make sure everyone is clear before operating machine or towing vehicle. 
- Never attempt to operate the implement unless you are in the driver's seat. 
- Never enter a cart containing grain. Flowing grain traps and suffocates victims in seconds. 

Before Servicing

- Avoid working under an implement; however, if it becomes absolutely unavoidable, make sure the implement is safely blocked. 
- Ensure that all applicable safety decals are installed and legible.
- To prevent personal injury or death always ensure that there are people who remain outside the cart to assist the person working inside the cart, and that all safe work place practices are followed. There is restricted mobility and limited exit paths when working inside the implement.
- Explosive separation of a tire and rim can cause serious injury or death. Only properly trained personnel should attempt to service a tire and wheel assembly.

Before Operating

- Do not stand between towing vehicle and implement during hitching.
- Always make certain everyone and everything is clear of the machine before beginning operation.
- Verify that all safety shields are in place and properly secured. 
- Ensure that all applicable safety decals are installed and legible.
- Secure drawbar pin with safety lock and lock tractor drawbar in fixed position.

During Operation

- Regulate speed to field conditions. Maintain complete control at all times.
- Never service or lubricate cart when in operation.
- Keep away from overhead power lines. Electrical shock can cause serious injury or death.
- Use extreme care when operating close to ditches, fences or on hillsides.
- Do not leave equipment unattended with engine running.



Before Transporting

- Secure transport chains to towing vehicle before transporting. **DO NOT** transport without chains.
- Check for proper function of all available transport lights. Make sure that all reflectors are clean and in place on machine. Make sure that the SMV emblem and SIS decal are visible to approaching traffic.
- This implement may not be equipped with brakes. Ensure that the towing vehicle has adequate weight and braking capacity to tow this unit.

During Transport

- Comply with all laws governing highway safety when moving machinery.
- Use transport lights as required by all laws to adequately warn operators of other vehicles
- Use good judgment when transporting equipment on highways. Regulate speed to road conditions and maintain complete control.
- Maximum speed of implement should never exceed 20 mph. Do not exceed 10 mph during off-highway travel.
- Slow down before making sharp turns to avoid tipping. Drive slowly over rough ground and side slopes.
- Do not transport grain cart on roads while loaded.
- It is probable that this implement is taller, wider and longer than the towing vehicle. Become aware of and avoid all obstacles and hazards in the travel path of the equipment, such as power lines, ditches, etc.

Driveline Safety

- Do not allow children near equipment that is running or engaged. 

- Do not exceed 1000 RPM PTO speed.

- Disengage the PTO, stop the tractor engine, and remove the key from the ignition before making inspections, or performing maintenance and repairs.

- Inspect the driveline, quick disconnect, overload shear-bolt limiter or clutch, and shielding often. Repair immediately. Use replacement parts and attaching hardware equivalent to the original equipment. Only alterations described in this manual for overall length adjustment are allowed. Any other alteration is prohibited.

- Avoid excessively long hardware or exposed and protruding parts which can snag and cause entanglement.

- Lubricate the driveline as recommended in the Maintenance section.

- Keep hoses, wiring, ropes, etc. from dangling too close to the driveline.

- Install the driveline and shields according to the recommended lengths and attaching methods with the recommended hardware. The driveline shield should rotate independently a full rotation and telescope freely. The retaining chain must be secured to the implement safety shield.

- Adjust the drawbar to the height recommended in the tractor set up section.

- Be careful not to hit the driveline with the tractor tires when turning.

- Check the length of the telescoping members to insure the driveline will not bottom out or separate when turning and/or going over rough terrain.

- Proper extended and collapsed lengths of the telescoping PTO shaft must be verified before first operation with each and every tractor. If the extended length of the PTO shaft is insufficient, it may become uncoupled during operation and cause serious injury or death from contact with uncontrolled flailing of the PTO shaft assembly components.

Pressurized Oil

- Relieve pressure before disconnecting hydraulic lines from tractor, loosening any hydraulic fittings or servicing hydraulic system. See hydraulic power unit manual for procedure to relieve pressure.
- High-pressure fluids can penetrate the skin and cause serious injury or death. Use cardboard or wood to detect leaks in the hydraulic system. Seek medical treatment immediately if injured by high-pressure fluids.
- Hydraulic system must be purged of air before operating to prevent serious injury or death.
- Do not bend or strike high-pressure lines. Do not install bent or damaged tubes or hoses.
- Repair all oil leaks. Leaks can cause fires, personal injury, and environmental damage.
- Route hoses and lines carefully to prevent premature failure due to kinking and rubbing against other parts. Make sure that all clamps, guards and shields are installed correctly.
- Check hydraulic hoses and tubes carefully. Replace components as necessary if any of the following conditions are found:
 - End fittings damaged, displaced, or leaking.
 - Outer covering chafed/cut or wire reinforcing exposed.
 - Outer covering ballooning locally.
 - Evidence of kinking or crushing of the flexible part of a hose.



Preparing for Emergencies

- Keep a first aid kit and properly rated fire extinguisher nearby.



- Keep emergency numbers for fire, rescue, and poison control personnel near the phone.



Wearing Protective Equipment

- Wear clothing and personal protective equipment appropriate for the job.



- Wear steel-toed shoes when operating.



- Wear hearing protection when exposed to loud noises.



- Do not wear additional hearing impairing devices such as radio headphones, etc.



SECTION II

Set Up

Set Up Checklist.....	2-2
Basic Cart Set Up	
Folding Side Extension Set Up	2-3
Ladder.....	2-3
Jack.....	2-3
Standard Chute Installation	2-3
Optional Extension Chute Installation.....	2-4
Driveline Storage.....	2-4
Wheel/Tire Set Up.....	2-5

Set Up Checklist

After the cart has been completely assembled, use the following checklist and inspect the cart. Check off each item as it is found satisfactory or after proper adjustment is made.

- Check that wheels are properly installed and torque wheel nuts as specified in MAINTENANCE section.
- Tires are inflated to specified air pressure. (If Applicable)
- All grease fittings have been lubricated and gearbox oil level checked.
- Check to be sure all safety decals are correctly located and legible. Replace if damaged.
- Check to be sure all reflective decals are correctly located.
- Check to be sure SMV decal is in place and shipping cover removed.
- Check to be sure transport lights are working properly.
- Check PTO. See “Verify Telescoping PTO Shaft Length” in MAINTENANCE section.
- Check to be sure screens over horizontal auger are in place and properly secured.
- Transport chains are properly installed and hardware is torqued to specification. See “Transport Chain Connection” in OPERATION section.
- Set tractor PTO control engagement setting to a minimum, refer to tractor operators manual for setting information.
- Paint all parts scratched in shipment.
- Test run the augers. See “Auger Operation” in OPERATION section.

Basic Cart Set Up

WARNING

- TO PREVENT PERSONAL INJURY OR DEATH, ALWAYS ENSURE THAT THERE ARE PEOPLE WHO REMAIN OUTSIDE THE CART TO ASSIST THE PERSON WORKING INSIDE, AND THAT ALL SAFE WORK PLACE PRACTICES ARE FOLLOWED. THERE IS RESTRICTED MOBILITY AND LIMITED EXIT PATHS WHEN WORKING INSIDE THE IMPLEMENT.

- EYE PROTECTION AND OTHER APPROPRIATE PERSONAL PROTECTIVE EQUIPMENT MUST BE WORN WHILE SERVICING IMPLEMENT.

- KEEP HANDS CLEAR OF PINCH POINT AREAS.

Your grain cart comes set up with exception of wheel/tire installation, side extensions, ladder, auger-extension chute, electrical hook-up to tractor, and tire pressure check. If your implement dealer has not set up the preceding items, the procedure is as follows:

Basic Cart Set Up (Continued)

Folding Side Extension

Hardware is stored behind right axle standard of grain cart.

1. Rotate extensions up into position and secure at corner holes.
2. Attach center support hardware.
3. Tighten all hardware, *including hinge bolts*.

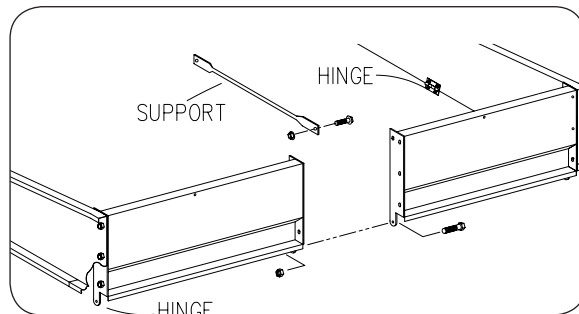

Ladder

Set ladder over mounting lugs and secure to front panel of cart.

Jack

⚠ WARNING

- UNHITCHING A LOADED GRAIN CART CAN CAUSE SERIOUS INJURY OR DEATH DUE TO TONGUE RISING OR FALLING. ALWAYS HAVE A LOADED GRAIN CART ATTACHED TO A TRACTOR. THE JACK IS INTENDED TO SUPPORT AN EMPTY GRAIN CART ONLY.

Remove jack from storage on front standard and install on mounting spud located on left side of frame behind hitch.

IMPORTANT

- Return jack to storage location after cart is hitched to tractor.

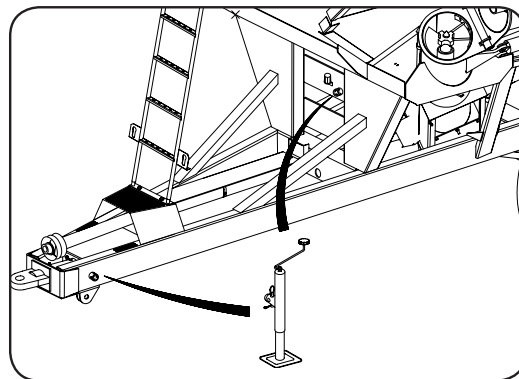

Standard Chute Installation

1. Position chute assembly over the upper auger tube outlet shroud with overlap towards hitch.
2. Hold with capscrew in top hole and secure with eight capscrews, flatwashers and locknuts.

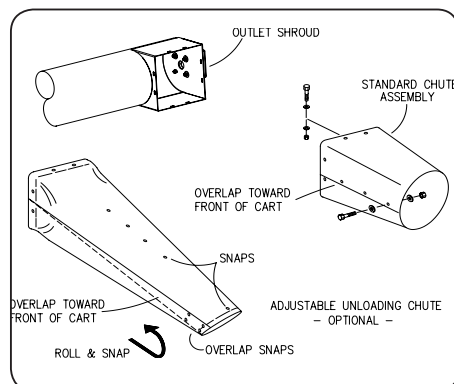

Basic Cart Set Up (Continued)

Optional Extension Chute Installation

1. Remove existing chute.
2. Fold overlap and snap four end snaps.
3. Slide chute over auger tube outlet shroud with overlap towards hitch.
4. Install top and bottom strips over chute and fasten with existing capscrews, flatwashers and locknuts.
5. To adjust to desired length, unsnap overlap, roll chute on outside and snap in place.

Driveline Storage

Storage brackets are located on the inside right frame rail. Secure the PTO shaft to these brackets for extended transporting or seasonal storage.

IMPORTANT

- *Remove and store the complete PTO before towing grain cart behind a delivery truck. Interference could occur when turning resulting in damage to PTO and cart.*

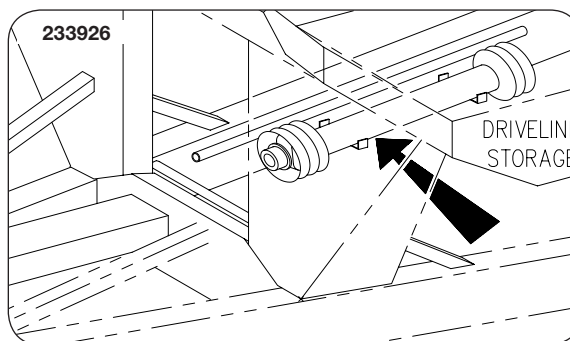

Lamp Set Up

Pivot lamp extension arms into position at sides of cart. If necessary, adjust lamp mounting position to achieve dimension shown. Ensure that amber reflectors are facing forward.

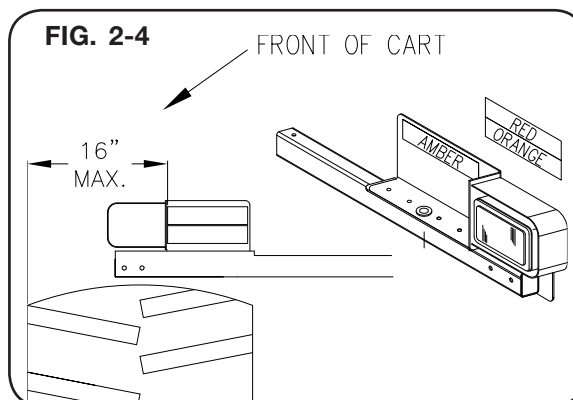

Basic Cart Set Up (Continued)

Wheel/Tire Set Up

Tire Pressure

Tire pressure must be verified before first use and adjusted as necessary. Refer to maintenance section of this manual for information on tire pressure.

Wheel Nuts

CAUTION

- IMPROPERLY TORQUED WHEEL NUTS/BOLTS CAN CAUSE A LOSS OF IMPLEMENT CONTROL AND MACHINE DAMAGE. WHEEL NUTS/BOLTS MUST BE CHECKED REGULARLY. SEE TORQUE PAGE IN THE “MAINTENANCE” SECTION FOR PROPER WHEEL NUT/BOLT SPECIFICATIONS. WARRANTY DOES NOT COVER FAILURES CAUSED BY IMPROPERLY TORQUED WHEEL NUTS/BOLTS.

IMPORTANT

- *Installing wheels without the proper inset could result in hub or spindle failure. This will cause substantial damage to cart.*

Notes

SECTION III

Operation

Preparing Tractor.....	3-2
Preparing Cart	
Inspection.....	3-3
Lubrication	3-3
Hitching To Tractor	
Drawbar Connection	3-4
Jack.....	3-4
Hydraulic Connections	3-5
Electrical Connections.....	3-6
Towing.....	3-8
Auger Operation.....	3-8
PTO-Driven Auger.....	3-9

Operating Checklist

- Read and understand all safety precautions before operating cart.
- Check axle spacing to be sure axle is adjusted from shipping position to desired operating width. (If Applicable)
- Check to be sure all the reflective decals and the SMV sign are clearly visible with the cart attached to the tractor. Check to be sure the transport lights are in working condition. Check and follow federal, state/provincial and local regulations before towing on a road or highway.
- Check to be sure PTO is correct length for making turns and operating on uneven terrain. See “Verify Telescoping PTO Shaft Length” in MAINTENANCE section.
- Torque wheel nuts and check tire pressure as specified in MAINTENANCE section.
- Transport chains are properly installed and hardware is torqued to specification. See “Transport Chain Connection” in OPERATION section.
- Check to be sure all screens and safety shields are in place.
- Check to be sure recommended lubrication procedures are being followed.
- Check operation and functionality of flow door, flow door indicator, auger fold, and auger pivot.
- Set tractor PTO control engagement setting to a minimum, refer to tractor operators manual for setting information.
- Test run the augers. See “Auger Operation” in OPERATION section.

Preparing Tractor

Before operating cart, read the tractor Operator’s Manual and gain an understanding of its safe methods of operation.

Check the tractor brakes and transport lights. Make sure they are in proper working order.

Check if the tractor has multiple PTO engagement modulation settings and has the latest PTO engagement software from the OEM. If unsure, contact your local dealer for tractor capabilities and recommended setting for grain cart operation.

Check the tractor hydraulic oil reservoir and add oil if needed.

Verify that the tractor is adequately ballasted for drawbar operation at the anticipated draft load. See tractor manual for ballasting instructions.

If possible, adjust the tractor drawbar vertically so the topside of the drawbar is approximately 17-22 inches from the ground. Ensure that the drawbar is locked in the center position.

On tractors equipped with a 3-point hitch, raise and secure the linkage to prevent interference with the cart tongue, hydraulic hoses and the hydraulic drive option during turning. It may be necessary to remove tractor 3-point quick attach to avoid damage during turning.

Preparing Cart

Inspection

Perform the service checks as outlined below. Repair or replace any damaged or worn parts before operating.

Hardware: Check for loose bolts and nuts, and tighten as needed. Check again after the first half-day of operation.

Pivot Pins: Check that all pins are in place and in good condition. Replace any worn, damaged, or missing pins.

Hydraulic System: Check all hoses and cylinders for signs of leakage. Hoses should not be kinked, twisted or rubbing against sharp edges. Re-route or repair hoses as necessary. Refer to SAFETY section for additional information on safe repair and inspection of hydraulic components.

Tires/Wheels: Check tire pressures and maintain at recommended values listed in the MAINTENANCE section of this manual.

CAUTION

- **IMPROPERLY TORQUED WHEEL NUTS/BOLTS CAN CAUSE A LOSS OF IMPLEMENT CONTROL AND MACHINE DAMAGE. WHEEL NUTS/BOLTS MUST BE CHECKED REGULARLY. SEE TORQUE PAGE IN THE “MAINTENANCE” SECTION FOR PROPER WHEEL NUT/BOLT SPECIFICATIONS. WARRANTY DOES NOT COVER FAILURES CAUSED BY IMPROPERLY TORQUED WHEEL NUTS/BOLTS.**

IMPORTANT

- *Installing wheels without the proper 1” inset could result in hub or spindle failure. This will cause substantial damage to cart and is not covered under warranty.*

For questions regarding new tire warranty, please contact your local original equipment tire dealer. Used tires carry no warranty. Tire manufacturers’ phone numbers and web sites are listed in the “MAINTENANCE” section of this manual for your convenience.

Lubrication

Lubricate the cart as outlined in the MAINTENANCE section of this manual.

Hitching To Tractor

Drawbar Connection

This cart is intended to be hitched to a tractor drawbar. Do not attempt to hitch to any other location on the tractor other than the drawbar.

The cart may be equipped standard with a single-tang hitch which utilizes a 1 1/2 inch diameter drawbar pin and must only be used with a clevis-type tractor drawbar. If the cart is equipped with a clevis-type hitch, remove the clevis from the tractor drawbar (if equipped).

The use of a smaller diameter hitch pin will result in additional clearance between the hitch and pin. This additional clearance may cause accelerated pin wear, tractor and cart hitch wear, along with more pronounced jolting from the cart during transport operation.

⚠ WARNING

- DO NOT STAND BETWEEN THE CART AND TRACTOR WHEN HITCHING. ALWAYS ENGAGE PARKING BRAKE AND STOP ENGINE BEFORE INSERTING HITCH PIN.

After inserting drawbar pin, secure drawbar pin with a locking device to help prevent uncoupling during use.

Jack

⚠ WARNING

- UNHITCHING A LOADED GRAIN CART CAN CAUSE SERIOUS INJURY OR DEATH DUE TO TONGUE RISING OR FALLING. ALWAYS HAVE A LOADED GRAIN CART ATTACHED TO A TRACTOR. THE JACK IS INTENDED TO SUPPORT AN EMPTY GRAIN CART ONLY.

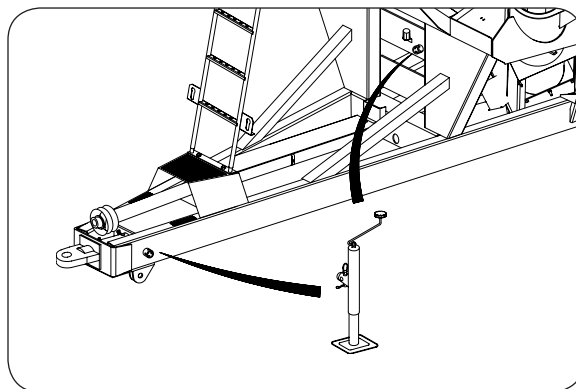

⚠ CAUTION

- ALWAYS USE TRANSPORT CHAIN WHEN TRANSPORTING IMPLEMENTS. FAILURE TO USE CHAIN COULD CAUSE PERSONAL INJURY IF IMPLEMENTS BECOME DISENGAGED.
- REPLACE TRANSPORT CHAIN IF ANY LINK OR END FITTING IS BROKEN, STRETCHED, OR DAMAGED. DO NOT WELD TRANSPORT CHAIN.

IMPORTANT

- Mount jack in storage location indicated after cart is hitched to tractor.

Hitching To Tractor (Continued)

Always use intermediate chain support when connecting grain cart directly to a tractor. **DO NOT** use the intermediate chain support as the chain attaching point. Fig. 6 shows how the transport chain must be installed between tractor and grain cart.

Transport chain should have a minimum rating equal to the gross weight of implement and all attachments. Use only ASAE approved chains. Allow no more slack in chain than necessary to permit turning.

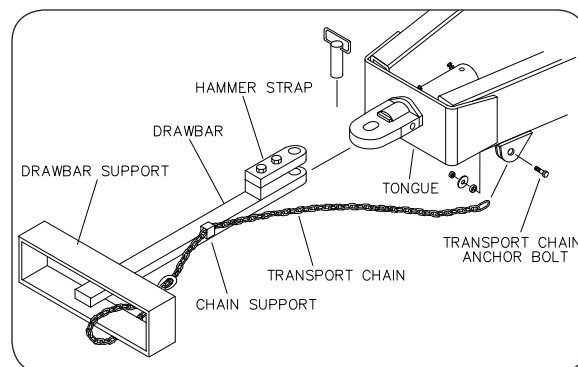

Hydraulics Connection

IMPORTANT

- When coupling hydraulic hoses to ports on tractor, be sure that coupler ends are clean of dust, dirt and debris. Failure to do so could contaminate hydraulic system resulting in excessive wear and possible failure.

Clean hydraulic hose couplers before connecting to tractor. For convenience it is recommended to connect the auger fold circuit hoses to tractor implement coupler #1, and the flow door circuit hoses to the highest-number coupler available on the tractor.

This unit is equipped with color bands attached to the hydraulic hoses. This will help in identifying the hose function and correct hook-up.

GREEN - AUGER FOLD

Raise Auger
Lower Auger

RED - FLOW DOOR

Flow Door Open
Flow Door Close

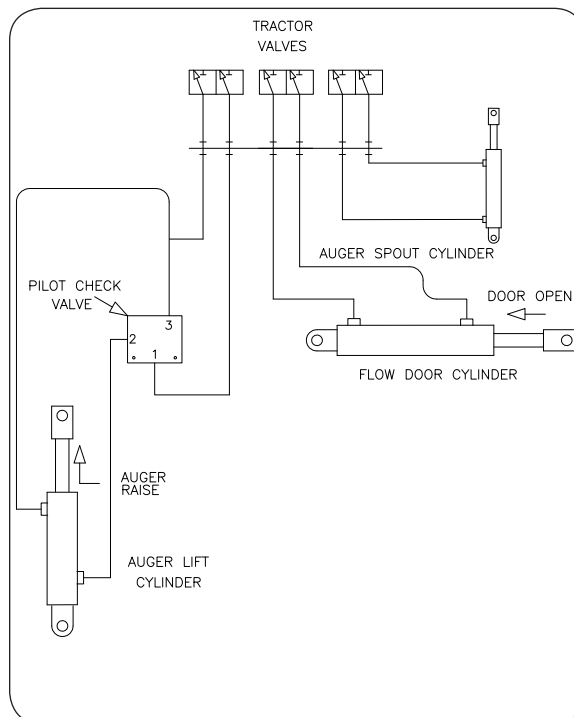

Hitching To Tractor (Continued)

After initial set-up or replacement of any hydraulic component on the cart, air must be removed from the cart hydraulic system. See Purge Procedure.

Route hoses away from areas that may cause abrasion or kinking of hoses during operation.

Before disconnecting hoses from the tractor, relieve pressure from the lines. See the tractor manual for the proper procedure to relieve the pressure. Shut off engine and apply parking brake before disconnecting hoses.

Electrical Connections

This cart is equipped with a seven-pin SAE connector plug which will connect with the receptacle found on most newer tractors. If your tractor does not have this type of receptacle, an SAE J-560 seven-point socket can be purchased from your Unverferth dealer (Part number 92824).

The wiring schematic for this cart, shown in the maintenance section, complies with ASABE Standards. Always verify correct electrical function before using this cart.

Compliance with all lighting and marking laws is the responsibility of the operator at the time of travel.

See federal regulation 49 CFR 562; available at www.govinfo.gov for US federal law requirements.

See your Killbros dealer for additional brackets, reflectors, or lights to meet your requirements.

Lamp Bracket Adjustment

The lamp bracket width is adjustable. Ensure that the brackets are adjusted such that the reflectors are no more than 16" from outer edge of the tires and that the amber reflectors are facing forward.

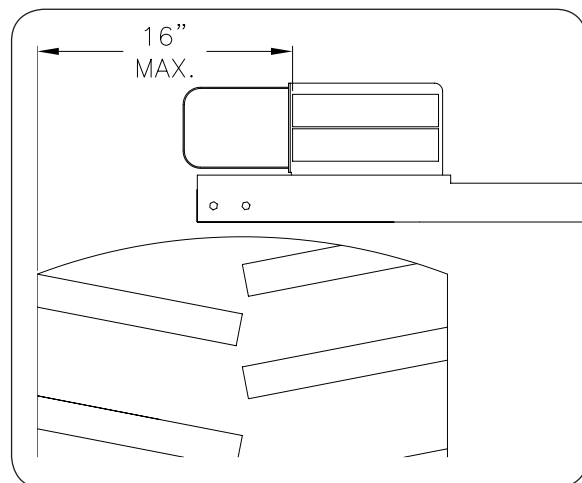

GRAIN CARTS — Operation

Hitching To Tractor (Continued)

GRAIN CART WIRES

- White -- Ground
- Green -- Right amber flashing lamp
- Yellow -- Left amber flashing lamp
- Brown -- Tail light
- Blue -- Auger Light

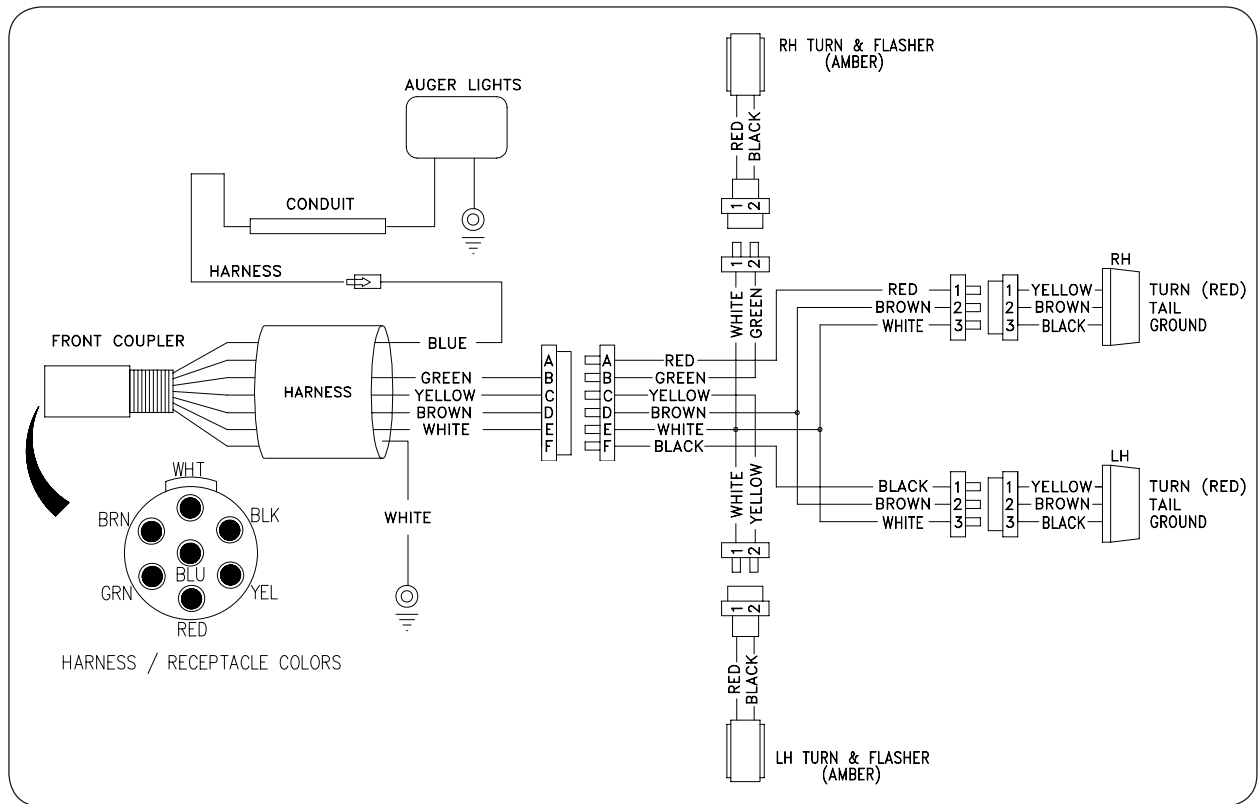
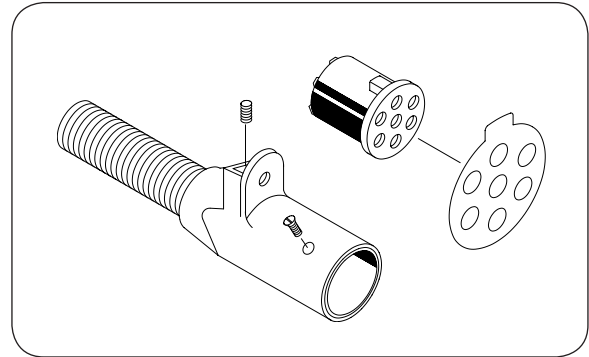

GRAIN CARTS — Operation

Towing

This cart is not equipped with brakes. Ensure that the towing vehicle has adequate weight and braking capacity to tow this implement. Never tow a loaded grain cart over public roads.

Do not exceed 10 mph during off-highway travel. Do not exceed 8 mph when cart is fully loaded.

Secure drawbar pin with a locking device and lock tractor drawbar in centered position. Connect the PTO driveshaft to the tractor.

Secure transport chain to tractor chain support before towing.



CAUTION

- THE STANDARD TRANSPORT CHAIN IS DESIGNED TO SUPPORT AN EMPTY GRAIN CART DURING ROAD TRAVEL
-

It is probable that this cart is taller, wider and longer than the towing tractor. Become aware of and avoid all obstacles and hazards in the travel path of the equipment, such as power lines, ditches, etc.

Always have auger folded back into storage position when auger is not in use.

To prevent damage during turning when using non-PTO equipped towing vehicles, store the PTO driveshaft in the brackets provided on the inside right frame rail.

Auger Operation



DANGER

- ELECTROCUTION WILL CAUSE SERIOUS INJURY OR DEATH. THE GRAIN CART IS NOT INSULATED. KEEP AWAY FROM ALL ELECTRICAL LINES AND DEVICES. ELECTROCUTION CAN OCCUR WITHOUT DIRECT CONTACT.
-



WARNING

- NEVER ENTER CART WITH AUGER OR TRACTOR RUNNING. SERIOUS INJURY OR DEATH CAN OCCUR DUE TO ENTANGLEMENT WITH ROTATING COMPONENTS. ALWAYS STOP ENGINE AND REMOVE KEY BEFORE ENTERING CART.
 - TO PREVENT PERSONAL INJURY OR DEATH, ALWAYS ENSURE THAT THERE ARE PEOPLE WHO REMAIN OUTSIDE THE CART TO ASSIST THE PERSON WORKING INSIDE, AND THAT ALL SAFE WORKPLACE PRACTICES ARE FOLLOWED. THERE IS RESTRICTED MOBILITY AND LIMITED EXIT PATHS WHEN WORKING INSIDE THE IMPLEMENT.
-

Auger Operation (continued)

PTO Driven Auger

DANGER

- ELECTROCUTION WILL CAUSE SERIOUS INJURY OR DEATH. THE GRAIN CART IS NOT INSULATED. KEEP AWAY FROM ALL ELECTRICAL LINES AND DEVICES. ELECTROCUTION CAN OCCUR WITHOUT DIRECT CONTACT.
- ENTANGLEMENT WITH THE DRIVELINE WILL CAUSE SERIOUS INJURY OR DEATH. KEEP ALL GUARDS AND SHIELDS IN GOOD CONDITION AND PROPERLY INSTALLED AT ALL TIMES. AVOID PERSONAL ATTIRE SUCH AS LOOSE FITTING CLOTHING, SHOE STRINGS, DRAWSTRINGS, PANTS CUFFS, LONG HAIR, ETC. THAT CAN BECOME EN-TANGLED IN A ROTATING DRIVELINE.

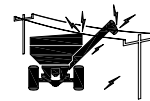

1. Before loading cart or operating auger, verify that the flow control door is closed.
2. Choose an area free from obstructions and unfold auger into unloading position. Allow sufficient time for the cylinder to fully engage the two augers.
3. Engage PTO at low RPM, then increase the PTO RPM to about 1000 RPM.

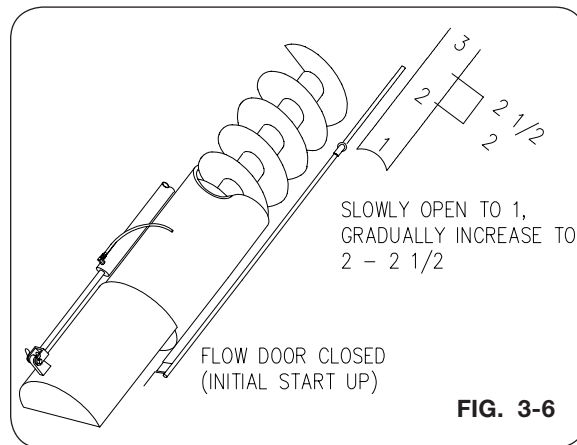

4. Open flow control door to desired unloading rate. Numbers on the auger tube provide a point of reference for operator convenience.

NOTE: If an overload occurs, (Shear-bolt failure or excessive heat/smoke from friction clutch) stop auger immediately. Close flow control door and relieve auger grain pressure by opening bottom door to remove some grain from auger before resuming.

5. To slow or stop grain flow, close flow door, rather than reducing tractor RPM. Close flow door fully when unloading is complete.

NOTE: It is not recommended to disengage auger with flow control door open. Auger system will require substantially more torque to start, placing extra stress on both cart and tractor driveline.

6. Stop PTO. After the PTO has come to a complete stop, fold auger to the transport position.

Notes

SECTION IV

Maintenance

Lubrication.....	4-2
Gearbox Lubrication	4-3
Seasonal Storage	4-3
Hydraulic System	4-4
Purge Hydraulic System	4-4
Relieving Hydraulic Pressure	4-5
Verify Telescoping PTO Shaft Length	4-6
Auger Driveline	
Bearings.....	4-8
Driveline Replacement	4-8
Gearbox.....	4-11
PTO Clutch Shear Bolt.....	4-11
PTO Shaft & Clutch.....	4-12
PTO Quick Disconnect Pin.....	4-14
Auger System	
Lower Auger	4-15
Upper Auger.....	4-16
Wheel Torque Chart & Tire Specifications	4-18
Tire Pressure	4-19
Tire Warranty	4-21
Torque Chart.....	4-22
Hydraulic Fittings	4-23

Lubrication

To keep your grain cart in top operating condition and to assure its proper performance and reliability for a long period of time, a periodic inspection and lubrication is a must.

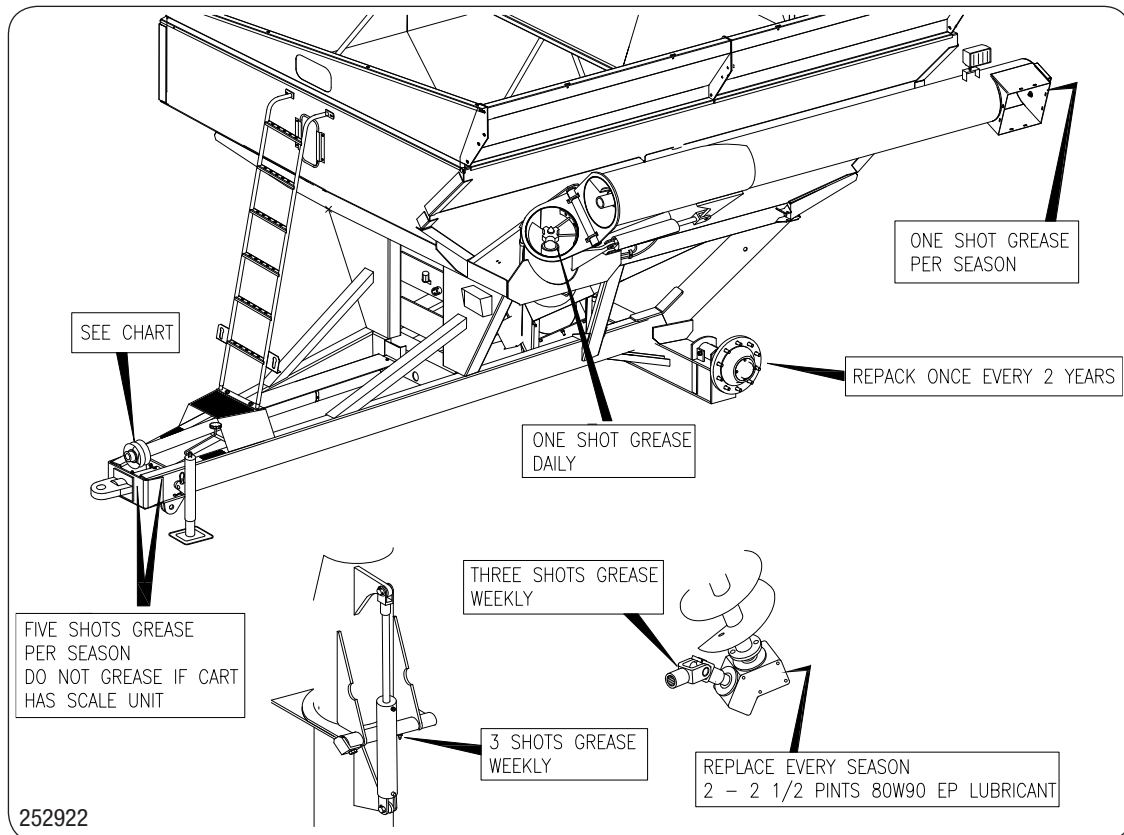

LUBRICATION INSTRUCTIONS FOR DRIVE LINE

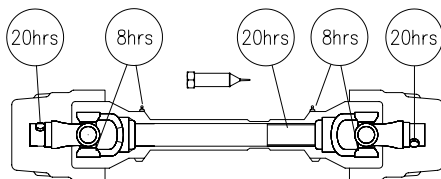

8hrs

20hrs

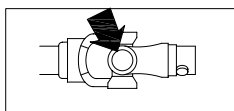

Cross journal

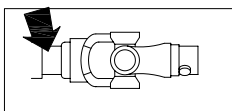

Inner tube

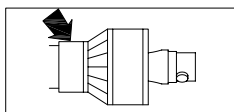

Shield retaining bearing

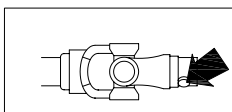

Push-pin set

COAT INNER AND OUTER PROFILES AT BEGINNING AND END OF EACH SEASON

250950

Gearbox Lubrication

Gearbox check/fill plug is located on the right hand front side of the housing. To check oil fluid level, place cart on a level surface with the tongue elevated to hitch height and remove the plug. Oil level should be at the bottom thread or approximately 5/8" below the outside gearbox surface.

For maximum gearbox life:

Check oil level every 2 weeks.

Replace oil every season with 32 fl. oz. of 80W90 EP gear lubricant.

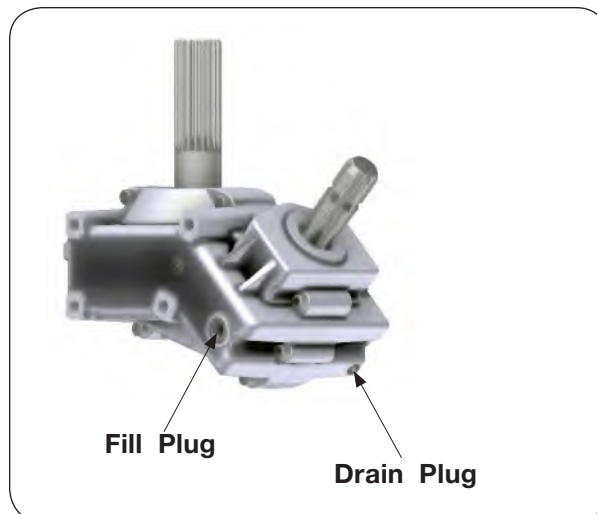

Seasonal Storage

Your cart is an important investment. Spend a little time to protect it from destructive rust and corrosion, You will be repaid in longer service life and better performance.

Do the following before placing the cart in storage:

1. Remove dirt and trash which could cause rusting.
2. Repaint any chipped or scraped areas.
3. Lubricate points as shown on previous page.
4. Inspect for damage or worn parts, replace before next season.
5. Store cart inside, away from livestock.
6. Replace all worn, torn or faded decals and reflectors.
7. Fully open flow door and auger cleanout door to remove any remaining grain and to allow moisture to drain.



Hydraulic System

Refer to parts section for hydraulic component detail listing.

When properly assembled and maintained, the hydraulic system of the grain cart requires little maintenance.

Replacing Hoses/Fittings/Cylinders:

1. Use replacement hoses, fittings, and cylinders from your Unverferth Manufacturing dealer which are rated for 3000 psi.
2. Do not use hoses, fittings and cylinders that have pipe threads.
3. Do not use Teflon tape or thread sealant on JIC or O-ring fittings. Tighten fittings according to “Torque Chart” in this section.
4. When replacing hoses, always allow sufficient slack to permit hoses to move through the full range of motion of the cylinders.
5. Always purge the hydraulic system after servicing.

Purge Hydraulic System

WARNING

- **HYDRAULIC SYSTEM MUST BE PURGED OF AIR BEFORE OPERATING TO PREVENT SERIOUS INJURY OR DEATH.**
- **RELIEVE HYDRAULIC SYSTEM OF ALL PRESSURE BEFORE ADJUSTING OR SERVICING. SEE THE HYDRAULIC POWER UNIT OPERATOR’S MANUAL FOR PROPER PROCEDURES.**
- **HIGH-PRESSURE FLUIDS CAN PENETRATE THE SKIN AND CAUSE SERIOUS INJURY OR DEATH. USE CARDBOARD OR WOOD TO DETECT LEAKS IN THE HYDRAULIC SYSTEM. SEEK MEDICAL TREATMENT IMMEDIATELY IF INJURED BY HIGH-PRESSURE FLUIDS.**
- **KEEP CLEAR OF PINCH POINT AREAS.**



Purge air from system as follows:

- A. Disconnect the rod end of all cylinders in a circuit and block up cylinders so the rod can completely extend and retract without contacting any other component.
- B. Pressurize the system and maintain system at full pressure for at least 5 seconds after cylinder rods stop moving. Check that all cylinders have fully extended or retracted.
- C. Check oil reservoir in hydraulic power source and refill as needed.
- D. Pressurize system again to reverse the motion of step B. Maintain pressure on system for at least 5 seconds after cylinder rods stop moving. Check that cylinders have fully extended or retracted.
- E. Check for hydraulic leaks using cardboard or wood. Tighten connections according to directions in Torque Chart.
- F. Repeat steps B, C, D, and E 3-4 times.
- G. Depressurize hydraulic system and connect cylinder rod clevises to their mating lugs.

IMPORTANT

- *Machine damage will occur if the cylinder is incorrectly installed.*

Check for and correct any leaks. Make sure hoses are not kinked, stretched, or twisted. Secure hoses to prevent cuts or chafing during operation.

Hydraulic System (continued)

Relieving Hydraulic Pressure

To relieve hydraulic pressure in the system, be sure hydraulic motor is disengaged and/or hydraulic cylinder is not exerting force on the system. Next, turn off engine and actuate valve in hydraulic system to all positions of actuation and to the neutral position. This should relieve all pressure in the system. If there is a need to remove hydraulic fittings or hoses, slowly loosen the appropriate connections. If there appears to be pressure in the system, retighten fitting at the top of this section and perform all procedures again until pressure is relieved.

Verify Telescoping PTO Shaft Length

WARNING

- **PROPER EXTENDED AND COLLAPSED LENGTHS OF THE TELESCOPING PTO SHAFT MUST BE VERIFIED BEFORE FIRST OPERATION. IF THE EXTENDED LENGTH OF THE PTO SHAFT IS NOT SUFFICIENT, IT MAY BECOME UNCOUPLED IN OPERATION AND CAUSE SERIOUS INJURY OR DEATH FROM CONTACT WITH UNCONTROLLED FLAILING OF PTO SHAFT ASSEMBLY COMPONENTS.**

An excessive collapsed length can result in damage to the PTO driveline and attached components. This is most likely to occur during extreme turning angles and/or travel over rough terrain. Damaged driveline components can result in unsafe operation and severely reduced driveline component life.

Note: Do not exceed 10 degrees beyond a straight pull line while operating the PTO.

To verify proper extended and collapsed lengths, use the following procedure:

1. Fully collapse PTO shaft and measure length “L” (Fig. 1).
Enter here: _____(1)
Verify that the outer tube does not bottom out on the surrounding plastic shield components.
2. Pull apart PTO telescoping shaft ends and measure lengths “T” & “C” (Fig. 2)
Add “T” + “C” measurements together Enter total here: _____(2)
3. Calculate maximum recommended extended length:
 - a. Subtract line 1 from line 2
Enter here: _____(a)
 - b. Divide line (a) by 2
Enter here: _____(b)
 - c. Add line (b) to line 1.
Enter here: _____(c)
 - d. Subtract 3 inches from line (c)
Enter here: _____(d)

This is the maximum recommended extended length.

4. Hitch the tractor drawbar to the cart, ensuring that the tractor and cart are on level ground and coupled as straight as practical.
5. Connect the PTO shaft to the tractor, and measure length “L” from same points as used in step 1. Ensure that this measurement does not exceed the maximum recommended extended length calculated in step 3 above. If necessary, choose a shorter drawbar position, or obtain a longer PTO shaft assembly before operating the cart.

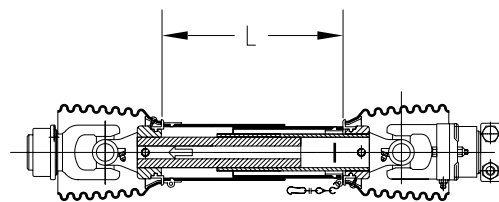

Fig. 1

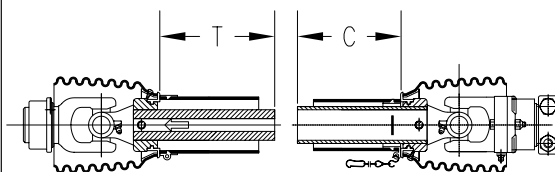

Fig. 2

Verify Telescoping PTO Shaft Length (Continued)

6. Position the tractor to obtain the tightest turning angle, relative to the cart (Fig. 3).
7. Measure the length “L” from the same points as used in step 1. **This distance must be at least 1.5 inches greater than the distance measured in step 1.** If necessary, adjust the length of the PTO shaft by cutting the inner and outer plastic guard tubes and inner and outer sliding profiles by the same length. Round off all sharp edges and remove burrs before greasing and reassembling shaft halves.

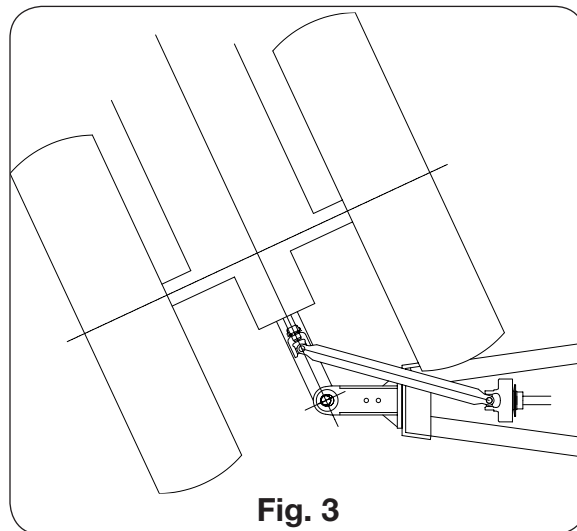

Fig. 3

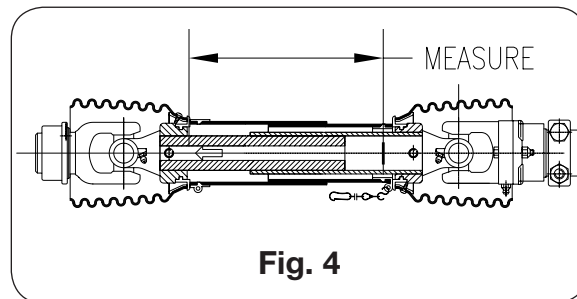

Fig. 4

Auger Driveline

Bearings

It is important to periodically check setscrews in all bearings of the driveline for tightness.

Driveline Replacement

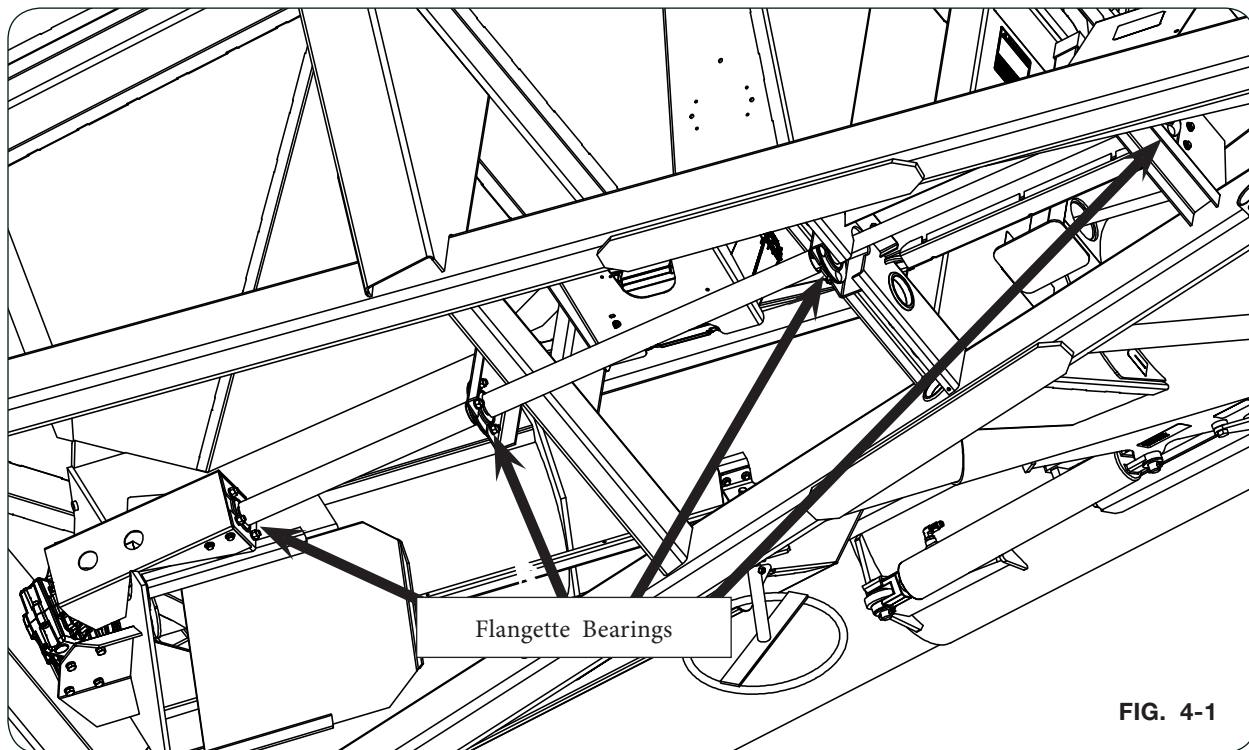

1. Park the empty cart on a firm, level surface. Block the wheels or tracks on the cart to keep it from moving. Set the tractor parking brake, shut off the engine, and remove the ignition key from the tractor before disconnecting driveline assembly and bearing hardware.

2. Loosen the setscrews (9399-071) on all flangette bearings (9003920) (Fig. 4-1).

3. Remove the 1/2" carriage bolts (9388-103), flange nuts (9394-010), and lock washers (9404-025) holding the flangette bearings. Keep hardware. (Fig. 4-2).

4. Remove paint on driveshaft to allow for easier movement. Slide driveshaft forward until the rear spline is out of the universal joint connected to the gearbox.

5. Drop the gearbox end of driveshaft down and slide driveshaft out of the flangette bearing on the hitch end of the driveshaft.

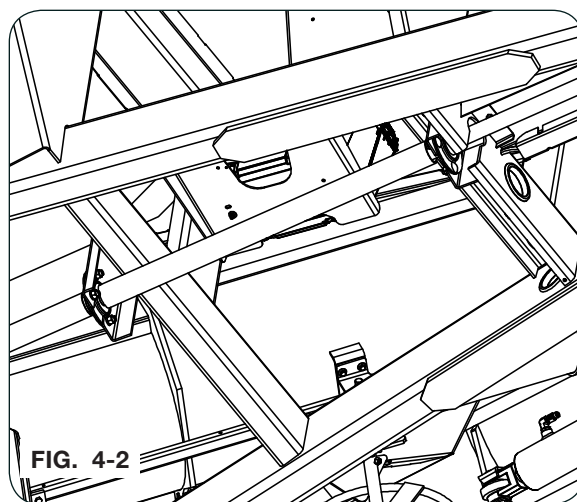

Auger Driveline (continued)

Driveline Replacement (continued)

6. Remove bearings, bearing mounts, universal joint cover, PVC driveshaft covers, and driveline cover, located behind the ladder, off the current driveshaft.
7. When installing new bearings (9003920) onto new driveshaft (9007718), assemble new 25" PVC driveshaft cover (291555) between bearings near the gearbox, and new 36" PVC driveshaft cover (291554) between bearings behind the hitch driveline cover. (FIG. 4-3)

NOTE: Ends of driveshaft are symmetrical.

8. Slide the hitch end of the driveshaft, bearing and hitch driveline cover into the bearing near hitch of the cart. (FIG. 4-3)
9. Raise the gearbox end of the driveshaft up and insert the original 1/2" carriage bolts, flange nuts, and lock washers into the mounting flanges making sure that the bearing flanges are both on the front side of the mounting brackets. Only loosely tighten the hardware.
10. Slide driveshaft down into the universal joint attached to the gearbox until the end of the shaft extends into the universal joint about 2 3/8". Ensure universal joint and driveshaft splines completely engage. Verify the hitch end for adequate length for driveline assembly to connect. (FIG. 4-4)

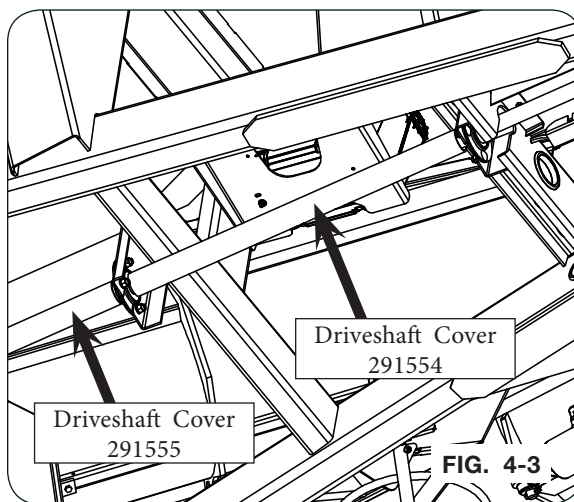

FIG. 4-3

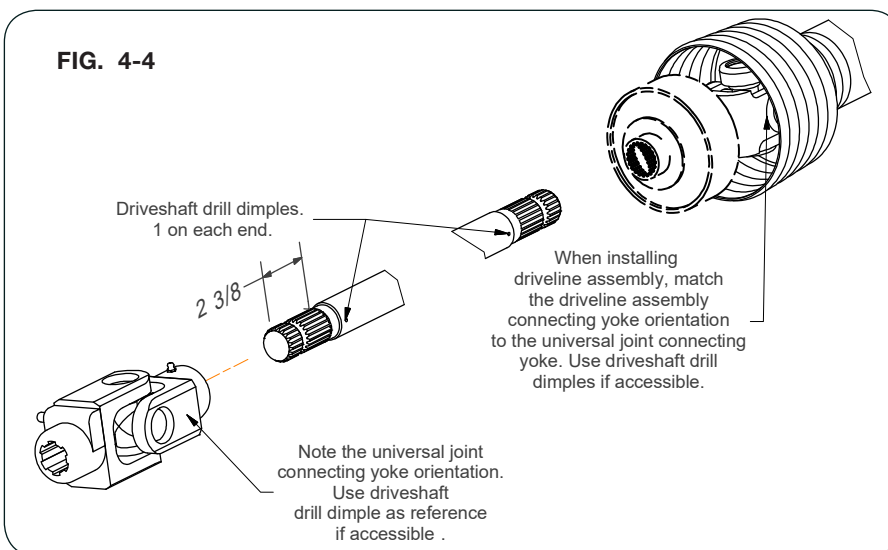

FIG. 4-4

Auger Driveline (continued)

Driveline Replacement (continued)

11. Tighten all flangette mounting hardware.
12. With bearing mounting hardware loosely tightened, drill a setscrew dimple in the driveshaft by going through the bearing setscrew threaded hole to dimple the driveshaft being careful to not damage threads. Drill the dimple to a depth that setscrews are flush with the bearing prior to applying thread locker and installing setscrews. (FIG. 4-5)
13. For alignment of the yoke, the orientation of the universal joint at the gearbox must be in line with the driveshaft drill dimple when the driveline assembly is attached. (FIG. 4-5, 4-6, and 4-7)

NOTE: Grease gearbox and universal joint before installing universal joint cover.

14. Attach new universal joint cover (290720B) to the bearing mount in front of the gearbox using original 3/8"-16UNC capscrews and 5/16"-18UNC weld nuts. Review to ensure PVC driveshaft covers and driveline cover, located behind the ladder, are in place and hardware tightened prior to operation.
15. Apply thread lock on bearing setscrews and tighten.
16. Test run driveline. Check for noise and/or vibration and address immediately.

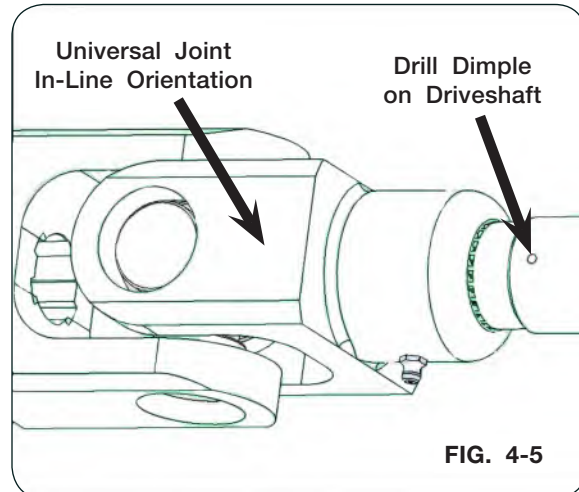

FIG. 4-5

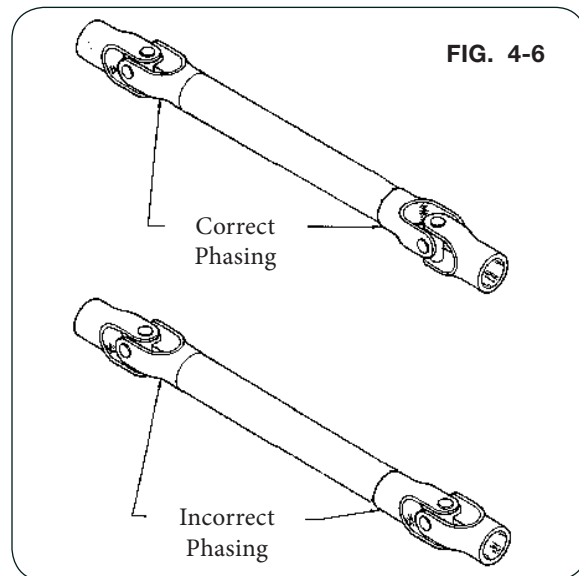

FIG. 4-6

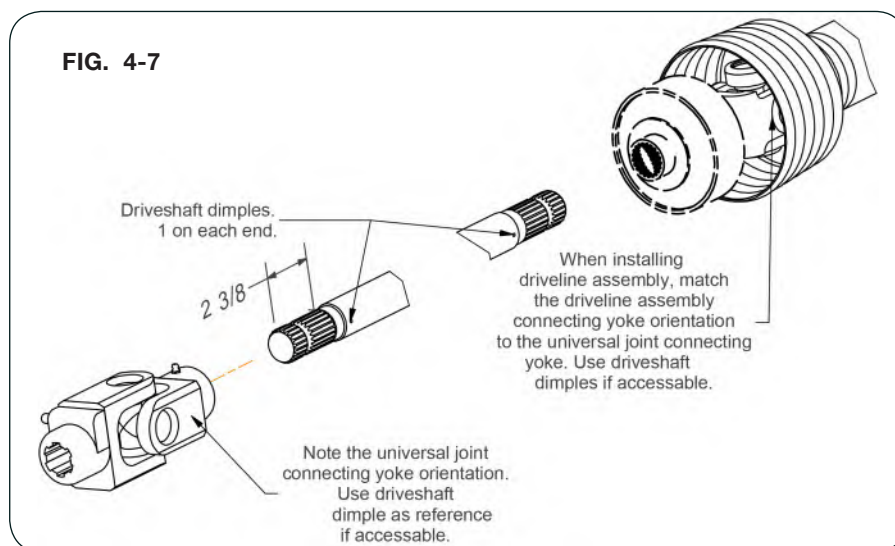

FIG. 4-7

Auger Driveline (continued)

Gearbox

Fluid level plug is on the right side of gearbox. Fill plug is in front of the axle on the left side of gearbox (Standing behind the cart looking toward the tractor).

For maximum gearbox life:

Check oil level every 2 weeks.

Replace oil every season, 2 - 2 1/2 pints 90 weight oil.

PTO Clutch Shear Bolt

This cart uses a shear bolt clutch to help protect the driveline from damage in the event of excessive driveline torque, such as when attempting to start a fully loaded auger.

The clutch is located at the cart-end of the extendable PTO driveshaft. Replace with the proper metric M8 x 50mm bolt and locknut and tighten to 20 FT-LBS torque. Use Part #94916-040.

NOTE: Use only a genuine OEM replacement shear bolt in this clutch. An incorrect shear bolt may cause the shear function to occur too soon, causing inconvenience, or too late, resulting in driveline or auger damage.

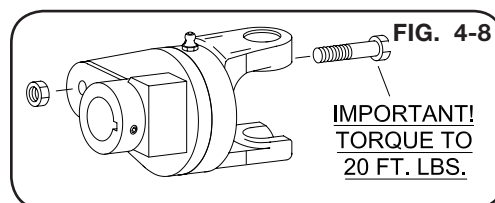

PTO Shaft & Clutch

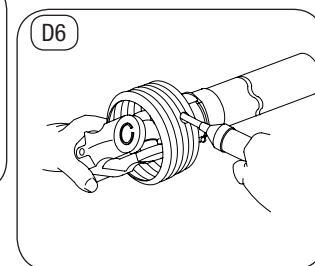
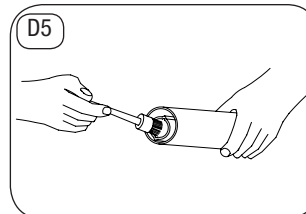
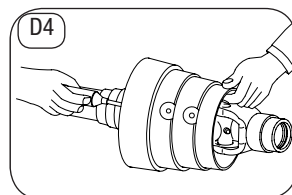
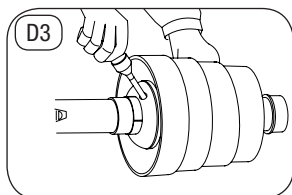
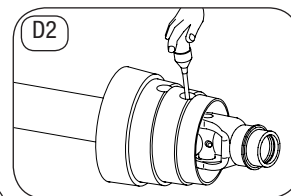
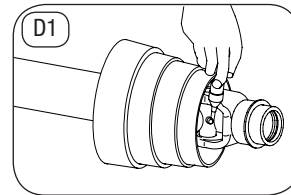
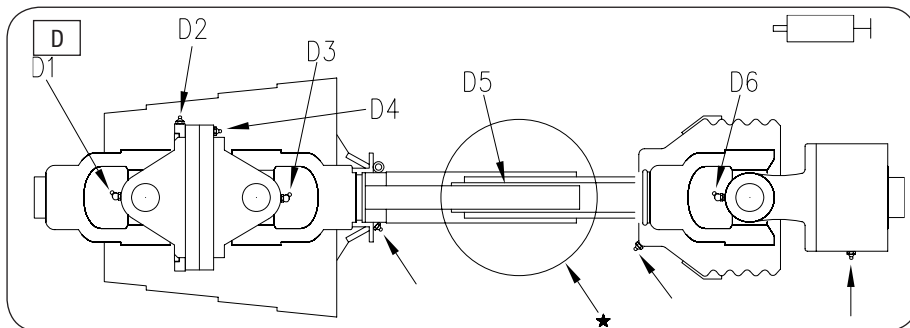

Lubrication

Lubricate with quality grease before starting work and every 8 operating hours. Clean and grease PTO drive shaft before each prolonged period of non-use.

Molded nipples on the shield near each shield bearing are intended as grease fittings and should be lubricated every 8 hours of operation!

Telescoping members must have lubrication to operate successfully regardless of whether a grease fitting is provided for that purpose! Telescoping members without fittings should be pulled apart and grease should be added manually. Check and grease the guard tubes in winter to prevent freezing.

Length Adjustment

1. To adjust length, hold the half-shafts next to each other in the shortest working position and mark them.
2. Shorten inner and outer guard tubes equally.
3. Shorten inner and outer sliding profiles by the same length as the guard tubes.
4. Round off all sharp edges and remove burrs. Grease sliding profiles.

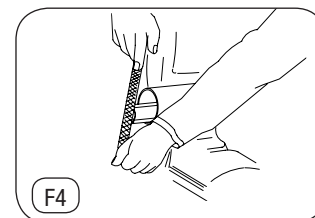
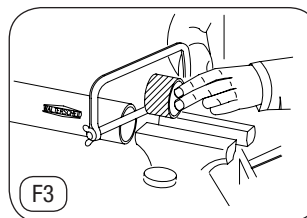
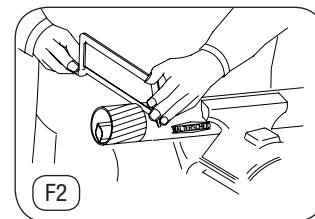
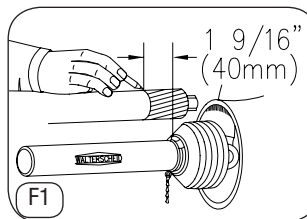

Check the length of the telescoping members to insure the driveline will not bottom out or separate when turning and/or going over rough terrain.

PTO Shaft & Clutch (Continued)

Dismantling Guard

1. Remove locking screw.
2. Align bearing tabs with cone pockets.
3. Remove half-guard.
4. Remove bearing ring.

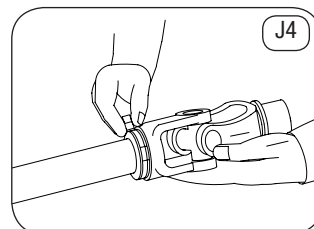
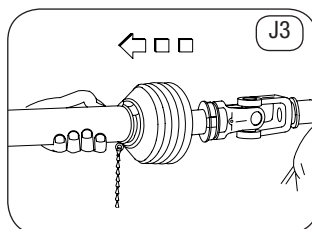
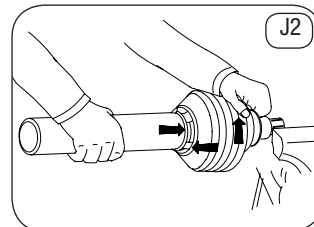
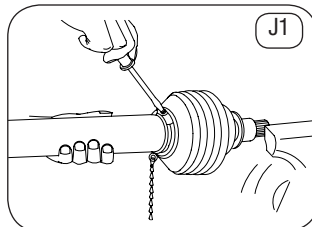

Assembling Guard

1. Grease yoke groove and inner profile tube.
2. Fit bearing ring in groove with recesses facing profile tube.
3. Slip on half-guard.
4. Turn cone until it engages correctly.
5. Install locking screw.

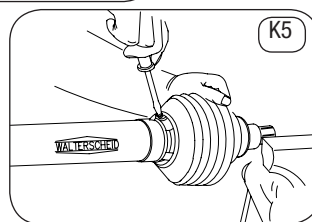
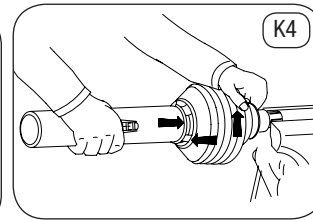
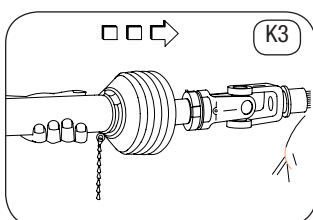
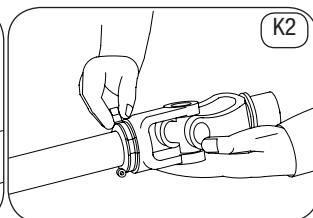
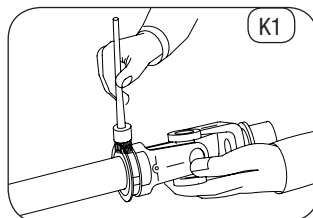

PTO Shaft & Clutch (Continued)

Assembling Cone

1. Dismantle guard (Figs. J1 - J3). Remove old cone (e.g. cut open with knife). Take off chain. Place neck of new cone in hot water (approx 80°C/180°F) and pull onto bearing housing (Fig. L1).
2. Turn guard cone into assembly position (Fig. L2). Further assembly instructions for guard (Figs. K1 - K5).
3. Reconnect chain if required (Fig. L3).

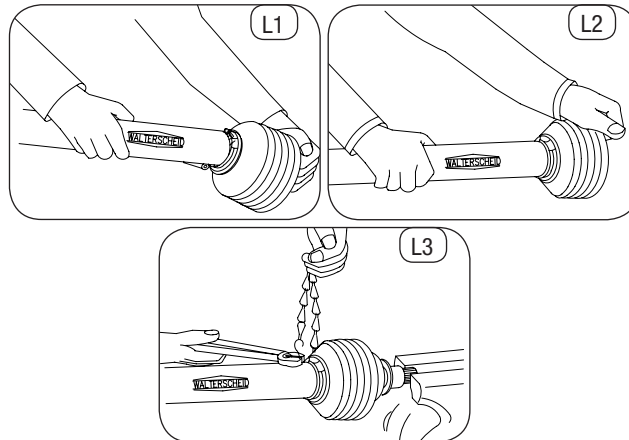

Quick Disconnect Pin

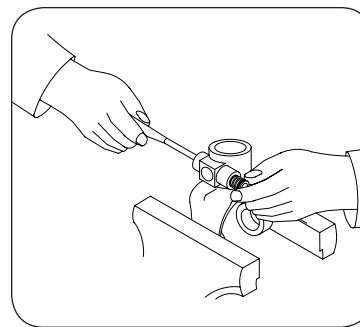
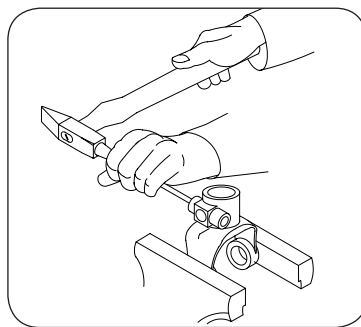
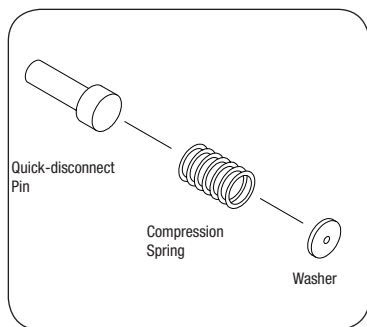

Using a drift punch and hammer, drive the pin towards the retaining washer to force the complete assembly out. Clear the edges of the retaining washer bore to accept the new one by removing the deformed metal from the last peening operation to hold the washer in place.

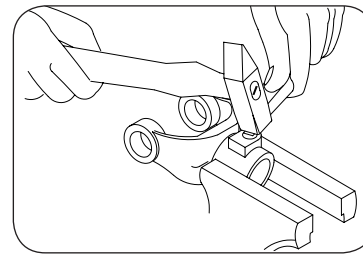
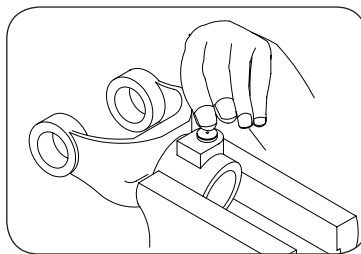
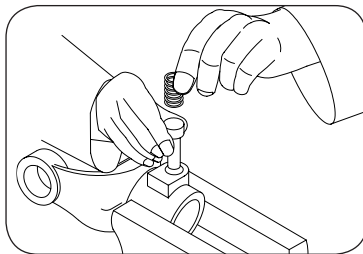

Insert quick-disconnect pin, compression spring and washer into hole.

Holding the washer in place, peen the edges of the bore seat to retain the washer, spring and pin.

Auger System

⚠ WARNING

- **FALLING OBJECTS CAN CAUSE SERIOUS INJURY OR DEATH. DO NOT WORK UNDER THE MACHINE AT ANY TIME WHILE BEING HOISTED. BE SURE ALL LIFTING DEVICES AND SUPPORTS ARE RATED FOR THE LOADS BEING HOISTED. THESE ASSEMBLY INSTRUCTIONS WILL REQUIRE SAFE LIFTING DEVICES UP TO 1200 LBS. SPECIFIC LOAD RATINGS FOR INDIVIDUAL LOADS WILL BE GIVEN AT THE APPROPRIATE TIME IN THE INSTRUCTIONS**

Lower Auger Disassembly

1. Park the unit on a firm, level surface. Block the wheels on the machine to keep it from moving. Set the tractor parking brake, shut off the engine and remove the ignition key from the tractor. Disconnect the PTO shaft from the tractor.
2. Remove three 3/8" x 1 1/4" capscrews (4), lock washers (5) and nuts (6) which secure hanger bearing to auger tube.
3. Using a safe lifting device rated at 500 lbs., remove auger from auger tube and perform required repair or replacement.
4. Remove two 5/8" x 6" capscrews (7) and locknuts (8) which trap hanger bearing and secure drive dog to auger.

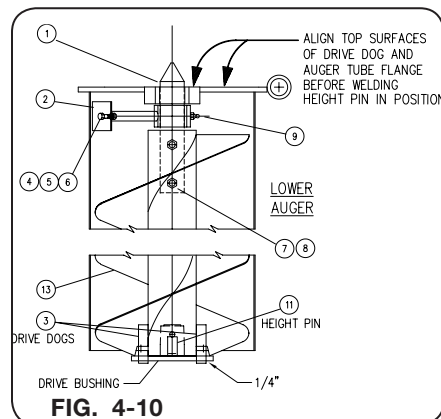

FIG. 4-10

Lower Auger Assembly

1. Assemble drive dog (1) and hanger bearing (2) to auger and secure with two 5/8" x 6" capscrews (7) and locknuts (8).
2. Install auger, drive dog, and hanger bearing into lower housing and secure with three 3/8" x 1 1/4" capscrews (4), lockwashers (5) and nuts (6). Do not Tighten.
3. Align the top surfaces of drive dog and auger tube flange. Tighten hanger bearing fasteners (4,5,6).
4. Rotate and align center auger tube until drive bushing holes are centered between flightings.

IMPORTANT

- *Disconnect cart completely from tractor before welding on equipment. Damage may occur to the electrical system.*
- *Disconnect all scale indicator leads, if applicable, before welding on equipment. Damage may occur to the indicator and load cells.*

Auger System (Continued)

5. Position height pin against top of drive bushing and weld to auger tube.

NOTE: Height pin can be located adjacent to one of drive pins and both pins welded together in Step 6.

6. Insert two lower drive dogs 1/4" through drive bushing and weld to auger center tube (and to height pin if applicable).
7. Raise upper auger into position, checking upper drive dog engagement with lower auger drive dog.
8. Lubricate hanger bearing. Check and remove any loose parts in auger tube interior prior to start-up.
9. Re-attach PTO to tractor and slowly rotate auger to ensure engagement and operation.

NOTE: The lower auger position is indexed from the drive dog/tube flange hinge surface as shown. The lower drive dogs and height pin are positioned relative to the gearbox and drive bushing.

NOTE: The alignment height of the auger can be changed by cutting loose and relocating the height pin.

Upper Auger Disassembly

1. Using a safe lifting device rated for 500 lbs., support the upper auger assembly with adequate hoist and slings.
2. Remove hose clamps and auger tube cylinder pin and carefully swing cylinder down without breaking hose connections.
3. Disconnect auger light.
4. With auger tube fully supported remove pivot pin keeper and hinge pin. Hinge pin end is center threaded to allow attachment of removal tool (ie: slide hammer).
5. Lift upper auger assembly from unit. Repair or replace as required.
6. To remove auger from tube, loosen two bearing setscrews and remove 5/16" x 2" machine screw retainer.
7. Inspect the upper auger bearing, springs, and four 1/2" x 5 1/2" capscrews and locknuts. Replace if necessary.

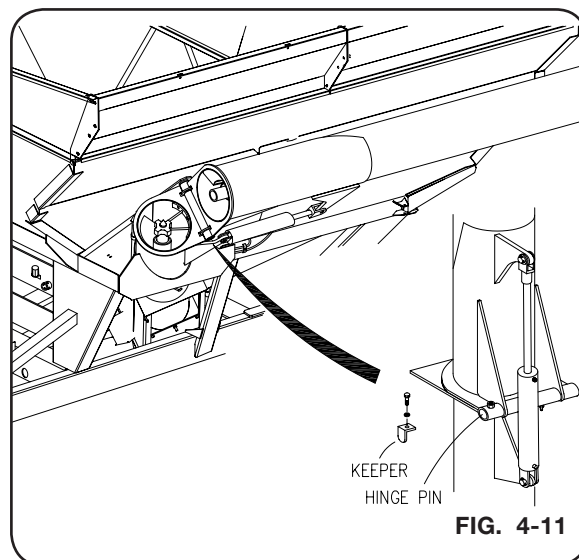

Auger System (Continued)

Upper Auger Assembly

1. Install the upper bearing and spring assembly if previously removed.
2. Using a safe lifting device rated for 500 lbs., insert auger in auger tube. Back out bearing setscrews and insert auger stub shaft through bearing. Retain auger with 5/16" x 2" machine screw and nut.
3. Position opposite auger end flush with auger tube flange and tighten bearing setscrews and 5/16" x 2" machine screw.
4. Lift upper auger assembly into position and install pivot pin and keeper.
5. Connect auger light.
6. Swing up hydraulic cylinder and reinstall pin and cotter pin. Clamp hoses into position and recheck connector tightness.

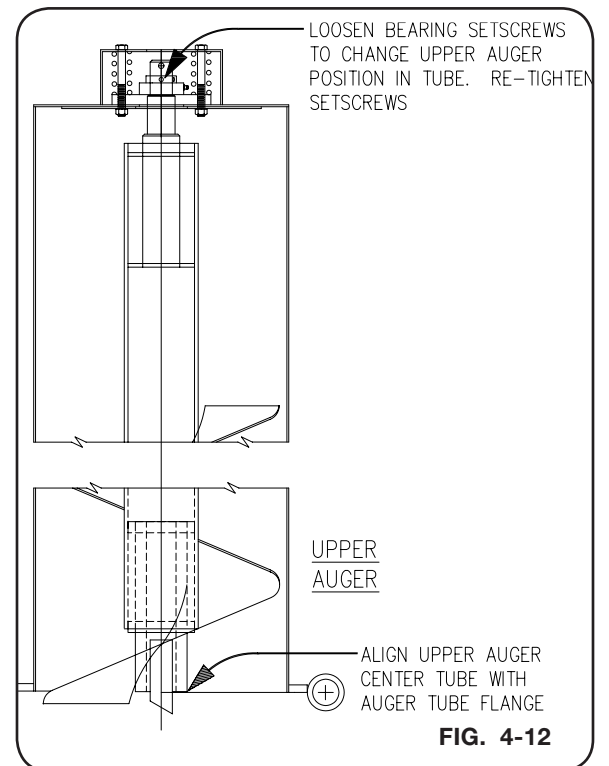

Wheel Torque Chart & Tire Specifications

Wheel Torque Requirements

⚠ CAUTION

- IMPROPERLY TORQUED WHEEL NUTS/BOLTS CAN CAUSE A LOSS OF IMPLEMENT CONTROL AND MACHINE DAMAGE. TORQUE WHEEL NUTS/BOLTS TO VALUES IN TABLE. CHECK TORQUE BEFORE INITIAL USE, AFTER ONE HOUR OF UNLOADED USE OR AFTER FIRST LOAD, AND EACH LOAD UNTIL WHEEL NUTS/BOLTS MAINTAIN TORQUE VALUE. CHECK TORQUE EVERY 10 HOURS OF USE THEREAFTER. AFTER EACH WHEEL REMOVAL START TORQUE PROCESS FROM BEGINNING. WARRANTY DOES NOT COVER FAILURES CAUSED BY IMPROPERLY TORQUED WHEEL NUTS/BOLTS.

Failure to check torque before first load may damage wheel nut/bolt seats. Once seats are damaged, it will become impossible to keep nuts/bolts tight. Tighten nuts/bolts to the applicable torque value shown below. Start all nuts/bolts by hand to prevent cross threading. Torque nuts/ bolts in the recommended sequence as shown in Diagram 1.

WHEEL HARDWARE	
SIZE	FOOT-POUNDS
3/4"-16 (UNF)	365 FT.-LBS.

Nut/Bolt Location:	
3/4"-16 (UNF)	Single Wheels

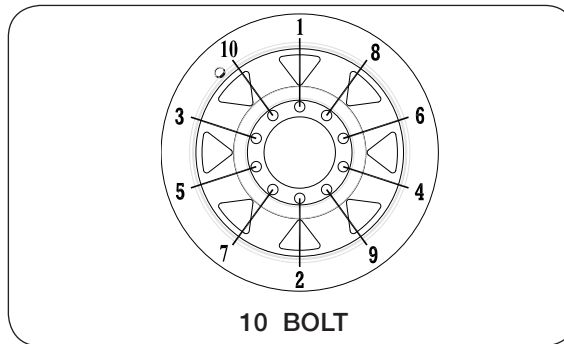

10 BOLT
DIAGRAM 1

Wheel Torque Chart & Tire Specifications (Continued)

Tire Pressure

The following is to be used as a general guide for tire inflation and figures can vary depending on specific brand of tire used. It is important that tires are inspected after unit is loaded. Start with minimum pressure indicated. The tire should stand up with no side-wall buckling or distress as tire rolls. Record the pressure needed to support the full load and maintain this pressure to achieve proper tire life. Do not exceed maximum recommended tire pressure. Each tire must be inflated to 35 PSI max to seat the beads, deflated to 5-10 PSI, then reinflated to the tire's max PSI when mounting.

Tire Pressure for Grain Carts			
Tire Make	Tire Size	Load Index / Ply Rating	Max. PSI
Firestone	23.1x26 R-3	12	32
	23.1x26 R-1	12	32
	28Lx26 R-3	12	26
	24.5x32 R-3	12	32
	24.5x32 R-1	12	32
	30.5x32 R-1	14	28
	30.5x32 R-3	14	28
	30.5x32 R-3	16	34
	30.5x32 R-1	16	26
	35.5x32 R-3	20	36
	76x50.00x32 HF-3	16	40
	76x50.00x32 HF-3	20	50
	800/65R32 R-1W	172A8	44
	800/60R32 R-3	181B	46
	900/65R32 R-3	191B	46
	900/60R32 R-1	176A8	44
	1250/50R32F IF/CFO R-1WNP	201D	46
	1250/50R32F IF/CFO R-1W	188B	30
	520/85R38 R-1	155A8	29
	520/85R38 R-1	173A8	64
	480/80R42 R-1	151A8	36
	520/85R42 R-1	157A8	29
	520/85R42 R-1	165A8	51
	520/85R42 IF/CFO R-1	169A8/B	35
	520/85R42 R-1W	169B	35
	420/80R46 R-1	151A8	44
	480/80R46 R-1	158A8	44
	380/90R46 R-1	152B	51

Wheel Torque Chart & Tire Specifications (Continued)

Tire Pressure

Tire Pressure for Grain Carts			
Tire Make	Tire Size	Load Index / Ply Rating	Max. PSI
Titan/Goodyear	23.1x26 R-3	10	26
	23.1x26 R-1	10	26
	24.5R32 R-1	169A8/B (5-Star)	48
	24.5x32 R-3	12	32
	24.5x32 R-1	12	32
	30.5x32 R-3	16	26
	30.5x32 R-3	14	22
	30.5x32 R-1	14	22
	480/80x42 R-1	166A8	23
	1100/45R46 F-1W	195D	35
Mitas	650/75R32 R-1W	172A8	58
	900/60x32 R-1W	176A8	41
	900/70R32 R-1W	188A8	53
	1050/50x32 R-1W	178A8	41
	1250/50R32 R-1W	188A8	41
	900/60x38 R-1W	181A8	44
	520/85x42 R-1W	162A8	44
	650/65x42 R-1W	168A8	44
Alliance	35.5LR32	193A8	44
	900/60R32 R-1W	192D	46
	1050/50R32 R-1W	185A8	63
Trelleborg	900/60x32 R-1	181A8	55
	900/60x32	176LI	44
	850/55R42 R-1W	161A8	32

*Each tire must be inflated to 35 PSI max to seat the beads, deflated to 5-10 PSI, then reinflated to the tire's max PSI.

Wheels and Tires (continued)

Tire Warranty

For questions regarding new tire warranty, please contact your local original equipment tire dealer. **USED TIRES CARRY NO WARRANTY.** Following are phone numbers and Websites for your convenience:

<u>Firestone</u>	www.firestoneag.com Phone 800-847-3364
<u>Titan</u> or <u>Goodyear</u>	www.titan-intl.com Phone 800-USA-BEAR Fax 515-265-9301
<u>Trelleborg</u>	www.trelleborg.com Phone 866-633-8473
<u>Continental/Mitas</u>	www.mitas-tires.com Phone 704-542-3422 Fax 704-542-3474
<u>Alliance</u>	www.atgtire.com Phone 781-325-3801

Complete Torque Chart

Capscrews - Grade 5

NOTE:

- Grade 5 capscrews can be identified by three radial dashes on the head.
- For wheel torque requirements, refer to Wheels and Tires.
- Tighten U-bolts evenly and equally to have the same number of threads exposed on each end.



SIZE	FOOT POUNDS	NEWTON METERS
1/4-20	8-10	11-13
1/4-28	9-11	12-15
5/16-18	15-17	20-23
5/16-24	17-19	23-26
3/8-16	25-28	34-38
3/8-24	28-31	38-42
7/16-14	40-45	54-61
7/16-20	45-50	61-68
1/2-13	62-68	84-92
1/2-20	68-75	92-102
9/16-12	90-98	122-133
9/16-18	100-110	134-148
5/8-11	120-135	162-183
5/8-18	124-137	168-186
3/4-10	200-220	270-300
3/4-16	210-230	285-310
7/8-9	330-350	425-475
7/8-14	360-380	460-515
1-8	500-525	675-710
1-14	540-560	730-760
1 1/8-7	600-635	815-860
1 1/8-12	665-700	920-950
1 1/4-7	850-895	1150-1215
1 1/4-12	940-990	1275-1340
1 3/8-6	1125-1175	1525-1590
1 3/8-12	1280-1335	1735-1810
1 1/2-6	1500-1560	2035-2115
1 1/2-12	1685-1755	2285-2380

IMPORTANT

- Follow these torque recommendations except when specified in text.

Hydraulic Fittings - Torque and Installation

SAE Flare Connection (J. I. C.)

1. Tighten nut with finger until it bottoms the seat.
2. Using a wrench, rotate nut to tighten. Turn nut 1/3 turn to apply proper torque.

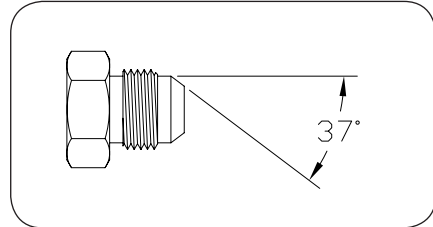

SAE Straight Thread O-Ring Seal

1. Insure jam nut and washer are backed up to the back side of smooth portion of elbow adapter.
2. Lubricate o-ring.
3. Thread into port until washer bottoms onto spot face.
4. Position elbows by backing up adapter.
5. Tighten jam nut.

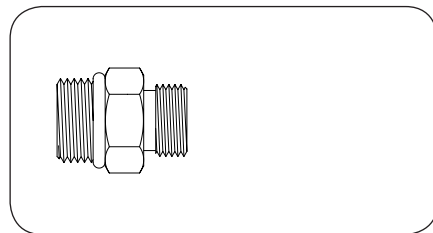

Notes

SECTION V

Parts

Final Assembly 5-2
Hitch 5-4
Axle 5-5
Hub - Model 1150 5-6
Hub - Model 1160 5-7
Wheels & Tires - Model 1150 5-8
Wheels & Tires - Model 1160 5-9
Decals 5-10
Sideboards 5-12
Electrical 5-14
Auger & Hydraulics 5-16
Upper Auger 5-18
Lower Auger & Driveline 5-19
Directional Downspout Control Kit #27122B (Optional) 5-20
Auger Chutes 5-22
Auger Cylinder 5-23
Flow Control Door Cylinder 5-23
PTO Assembly 5-24
PTO Clutch 5-25
50° Gearbox 5-26
Driveline U-Joint Assembly 5-27

PLEASE REFER TO THE APPROPRIATE ACCESSORY MANUAL IF EQUIPPED:
SCALES
HYDRAULIC DRIVE
WEATHER GUARD TARP

GRAIN CARTS — Parts

Final Assembly

Please visit www.unverferth.com/parts/ for the most current parts listing.

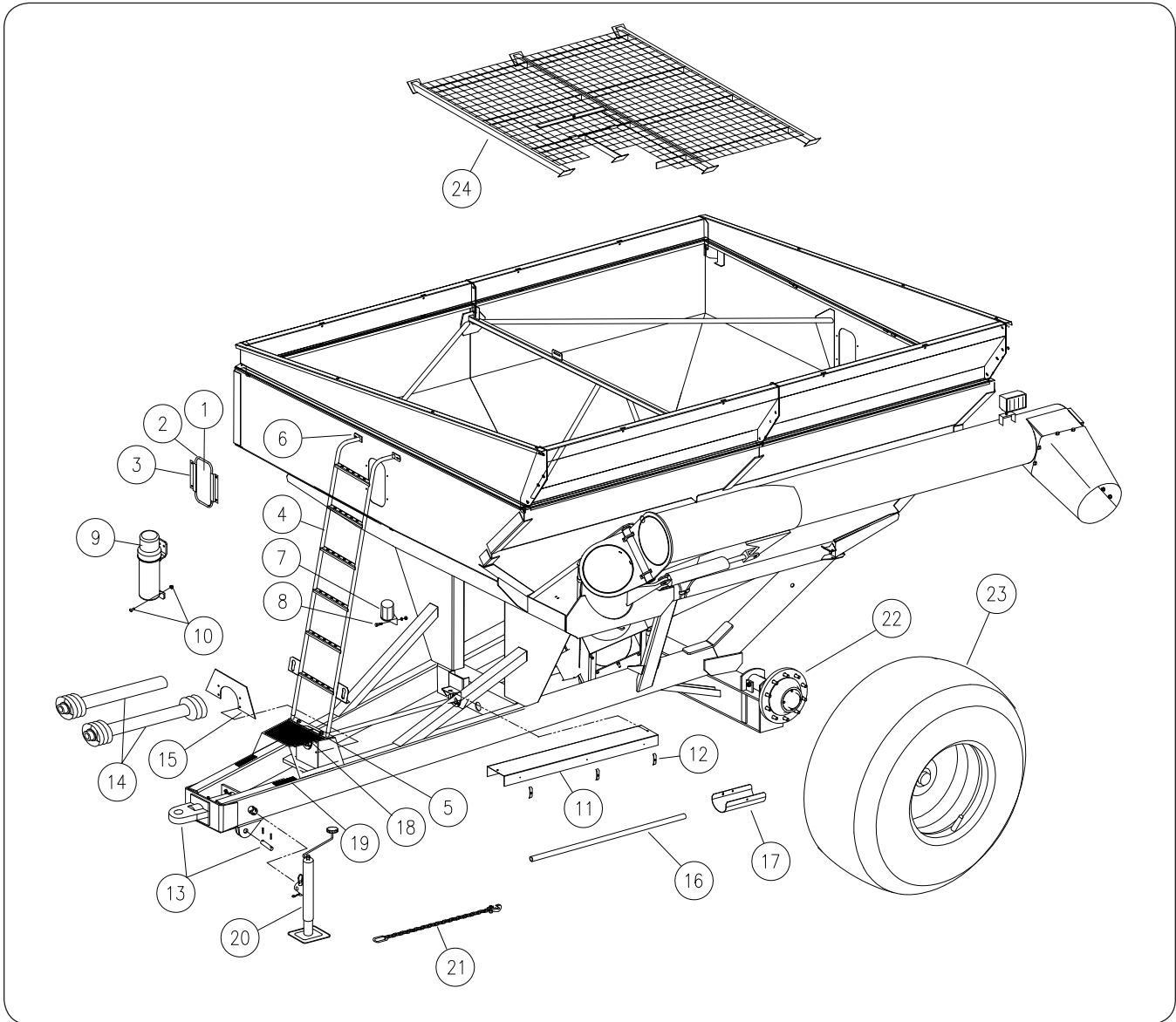

GRAIN CARTS — Parts

Final Assembly

Please visit www.unverferth.com/parts/ for the most current parts listing.

ITEM	DESCRIPTION	PART NO.	QTY.	NOTES
1	Window	92403	2	
2	Window Molding	250431	3	
3	Bracket, Window Retaining	250461B	4	
	Capscrew, 1/4"-20UNC x 3/4"	9390-003	8	
	Flat Washer, 1/4"	9405-064	8	
	Locknut, 1/4"-20UNC	9936	8	
4	Ladder Weldment	253093B	1	
5	Bracket, Ladder Weldment	252007B	1	
6	Flange Screw, 3/8"-16UNC x 3/4"	95585	4	
	Flange Nut, 3/8"-16UNC	91263	2	
7	Connector Holder	9001968	1	
8	Capscrew, 1/4"-20UNC x 3/4"	9390-003	2	
	Lock Washer, 1/4"	9404-017	2	
	Hex Nut, 1/4"-20UNC	9394-002	2	
9	Manual Tube	900552	1	
10	Machine Screw 1/4"-20UNC x 3/4"	903174-535	2	Phillips Truss Head
	Flange Hex Nut, 1/4"-20UNC	97189	2	
11	Shield, PTO	253162B	1	54 1/2" Long
12	Hose Clamp, 3"	807382B	3	
13	Hitch	Page 5-4		
14	PTO	Page 5-24		
15	Plate, PTO	253166B	1	
16	Hose Tube, Plastic	253112	1	1 1/2 x 37"
17	Guard, PTO Shaft	2009370B	1	
18	Pad, PTO Shaft	9001496	1	
19	Pad, Runner	9001497	2	
20	Jack Assembly	9003299	1	
21	Transport Chain	94098	1	
22	Axle Assembly	Page 5-5	1	
23	Wheel	Page 5-8 & Page 5-9		
24	Screen Weldment	253101	1	

PAINT	SPRAY
Black	97013
Green	97015
Red	97301
Off-White	97016
Primer, Gray	9500082

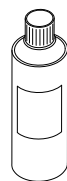

265915

GRAIN CARTS — Parts

Hitch

Please visit www.unverferth.com/parts/ for the most current parts listing.

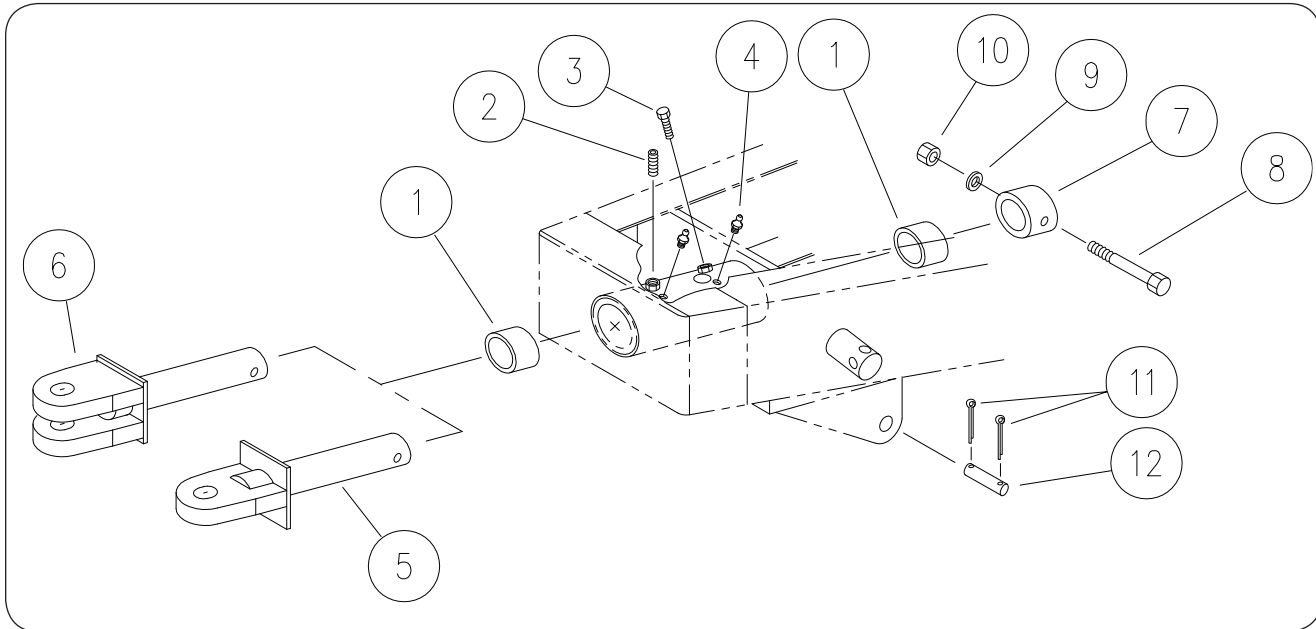

ITEM	DESCRIPTION	PART NO.	QTY.	NOTES
1	Swivel Hitch Insert Bushing	7-0063	2	Remove from Scale Hitch
2	Setscrew, 1/2-13 UNC x 1 1/4	9399-111	1	
3	Capscrew, 1/2-13 UNC x 1 1/4	9390-100	1	
4	Grease Zerk	91160	2	
5	Swivel Hitch, Single Tang	200002B	1	Option - 1150
6	Swivel Hitch, Clevis	200029B	1	Option - 1160
7	Retainer	200031B	1	
8	Capscrew, 1-8 UNC x 6	9390-195	1	
9	Lock Washer, 1	9404-041	2	
10	Hex Nut, 1-8 UNC	9394-020	2	
11	Cotter Pin, 3/16 Dia. x 2	9391-046	2	
12	Pin, Transport Chain	804572	1	1 x 3 1/2"

GRAIN CARTS — Parts

Model 1150 Axle

Please visit www.unverferth.com/parts/ for the most current parts listing.

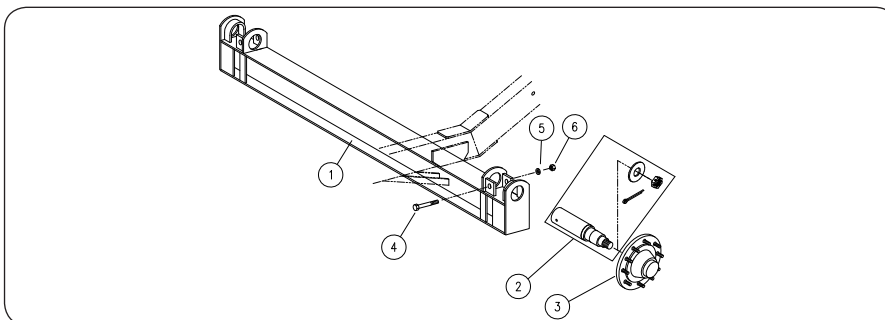

ITEM	DESCRIPTION	PART NO.	QTY.	NOTES
	Axle Assembly - 120" =Green=	253176G-SER	1	Includes Items 1-6
	Axle Assembly - 120" =Red=	253176R-SER		
	Axle Assembly - 144"	-	Opt.	
1	Axle Weldment - 120" =Green=	253163G	1	
	Axle Weldment - 120" =Red=	253163R		
	Axle Weldment - 144"	-		
2	Spindle, 2 7/8" Dia.	200242	2	Incl. 200241, Nut, Washer, & C'Pin
	Spindle, 2 7/8" Dia. - Scale (Weigh Tronix)	254263	2	Incl. 9002642, Nut, Washer, & C'Pin
3	Hub	-	2	See Page 5-6
4	Capscrew, 5/8-11 UNC x 6	9390-136	2	
5	Lock Washer, 5/8	9404-029	2	
6	Hex Nut, 5/8-11 UNC	9394-014	2	

Model 1160 Axle

ITEM	DESCRIPTION	PART NO.	QTY.	NOTES
	Axle Assembly - 120" =Green=	234071G-SER	1	Includes Items 1-6
	Axle Assembly - 120" =Red=	234071R-SER		
1	Axle Weldment - 120" =Green=	234042G	1	
	Axle Weldment - 120" =Red=	234042R		
2	Spindle, 3 3/4" Dia.	234073	2	Incl. 234072, Nut, Washer, & C'Pin
	Spindle, 3 3/4" Dia. - Scale (Weigh Tronix)	254261		Incl. 9003611, Nut, Washer, & C'Pin
3	Hub	-	2	See Page 5-7
4	Capscrew, 5/8-11 UNC x 5 1/2	9390-135	2	
5	Lock Washer, 5/8	9404-029	2	
6	Hex Nut, 5/8-11 UNC	9394-014	2	

GRAIN CARTS — Parts

Model 1150 Hub

Please visit www.unverferth.com/parts/ for the most current parts listing.

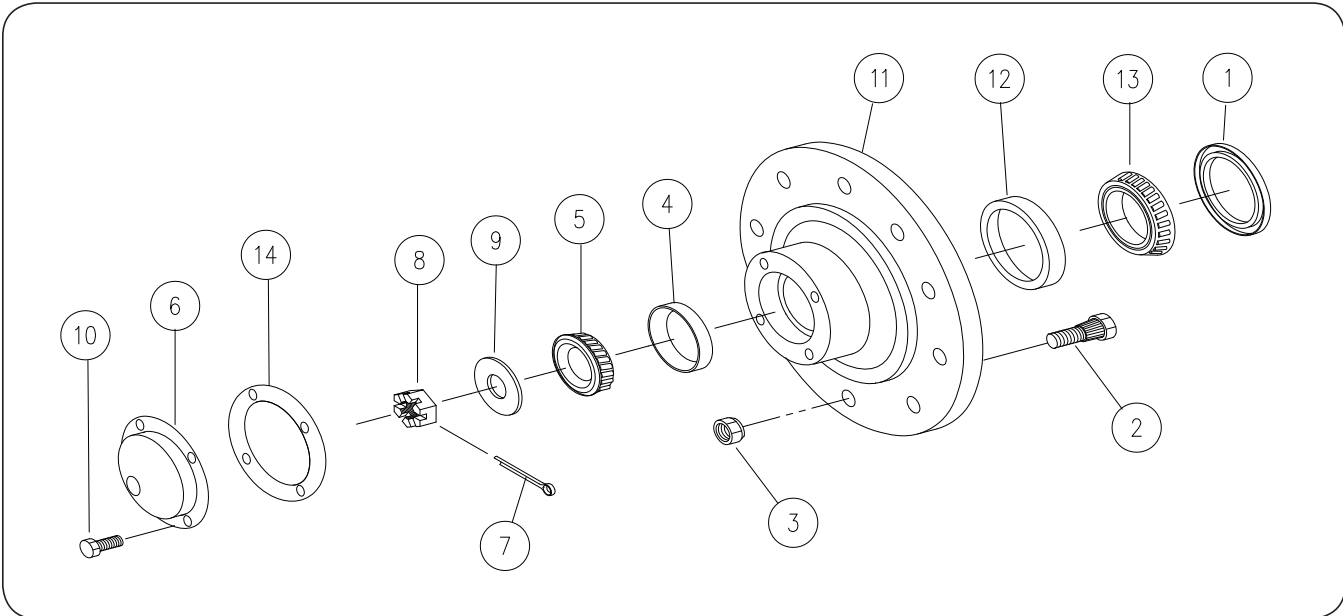

ITEM	DESCRIPTION	PART NO.	QTY.	NOTES
	Hub Assembly, Complete =Green=	200036G	1	Includes Items 1-6 & 10-13
	Hub Assembly, Complete =Red=	200036R		
1	Seal	92456	1	
2	Stud Bolt 3/4-16 UNF x 3	94794	10	Grade 8
3	Wheel Nut 3/4-16 UNF	92458	10	Grade 8
4	Outer Bearing Cup, 4 1/4 OD	92461	1	
5	Outer Bearing Cone, 2 1/4 ID	9002954	1	
6	Hub Cap w/ 4 Holes & Grease Zerk	281881	1	
	Grease Zerk	91160	1	
7	Cotter Pin 1/4 Dia. x 3	9391-062	1	
8	Slotted Nut 1/4-12 UNF	9002721	1	Grade 5
9	Washer 3 1/4 OD	233727	1	
10	Capscrew, 5/16-18 UNC x 1/2	9390-026	4	Grade 5
11	Hub w/Bearing Cups & Studs =Green=	200037G	1	Includes Items 2,4,12 & Hub
	Hub w/Bearing Cups & Studs =Red=	200037R		
12	Inner Bearing Cup, 4 5/8 OD	92475	1	
13	Inner Bearing Cone, 2 3/4 ID	92546	1	
14	Gasket	284229	1	

GRAIN CARTS — Parts

Model 1160 Hub

Please visit www.unverferth.com/parts/ for the most current parts listing.

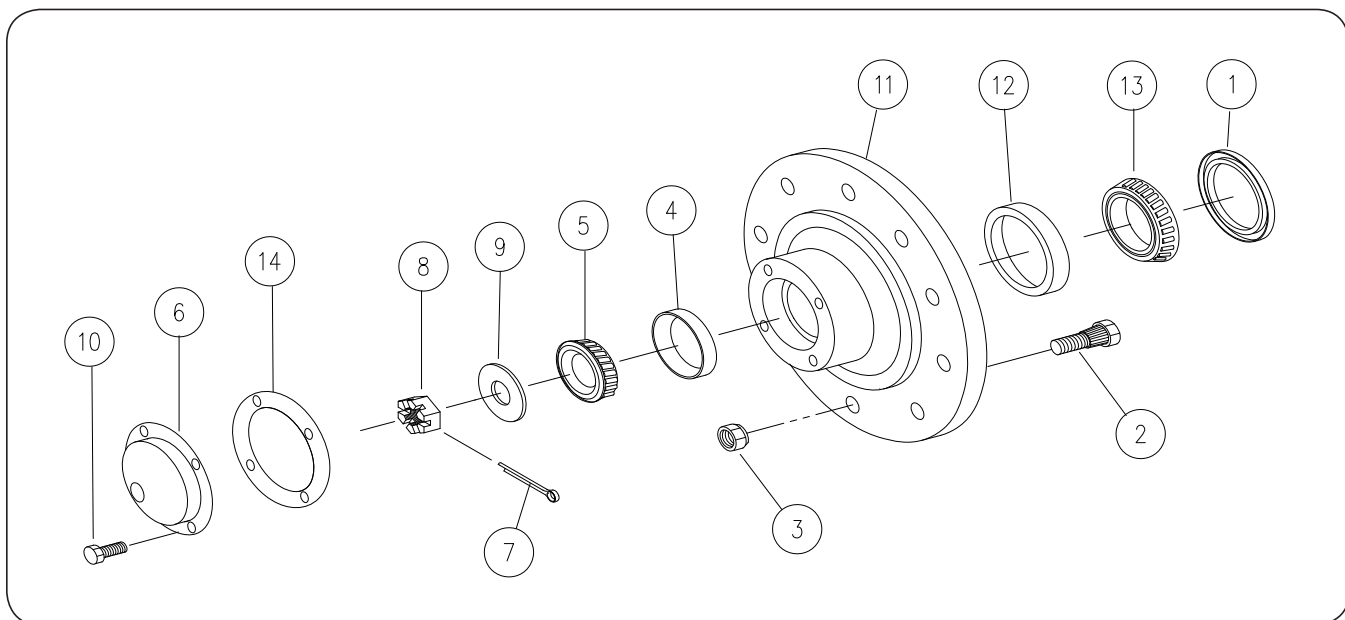

ITEM	DESCRIPTION	PART NO.	QTY.	NOTES
	Hub Assembly, Complete =Green=	200079G	1	Includes Items 1-6 & 10-13
	Hub Assembly, Complete =Red=	200079R		
1	Seal	92565	1	
2	Stud Bolt 3/4-16 UNF x 3	94794	10	Grade 8
3	Wheel Nut 3/4-16 UNF	92458	10	Grade 8
4	Outer Bearing Cup	92462	1	
5	Outer Bearing Cone, 2 5/8 ID	92464	1	
6	Hub Cap w/ 4 Holes & Grease Zerk	286171	1	
	Grease Zerk	91160	1	
7	Cotter Pin 3/8 Dia. x 4	9391-090	1	
8	Castle Nut, 2-12 UNF	92470	1	Grade 5
9	Washer 4 OD	92472	1	
10	Capscrew, 5/16-18 UNC x 1/2	9390-026	4	Grade 5
11	Hub w/Bearing Cups & Studs =Green=	200039G	1	Includes Items 2,4,12 & Hub
	Hub w/Bearing Cups & Studs =Red=	200039R		
12	Inner Bearing Cup	92476	1	
13	Inner Bearing Cone	92545	1	
14	Gasket	284230	1	

GRAIN CARTS — Parts

Model 1150 Wheels & Tires

Please visit www.unverferth.com/parts/ for the most current parts listing.

TIRES
 For questions regarding new tire warranty, please contact your local original equipment tire dealer. Used tires carry no warranty. Tire manufacturers' phone numbers and websites are listed in Maintenance Section for your convenience.

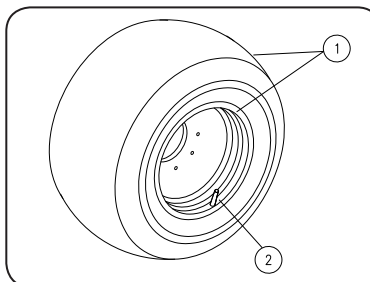

ITEM	DESCRIPTION	PART NO.	QTY.	NOTES
				10 Hole Wheels, 8.78" Pilot, 11.25" B.C.
1	Wheel & Tire Assembly	14992	2	TL24.5x32 10-Ply (Minimum) R-1 Used
	Wheel Only	111128WO	2	21 x 32
	Tube	*	-	24.5 x 32
	Plug, 1 1/4"	92623	2	
1	Wheel & Tire Assembly	14308	2	TL520/85R38F R-1
	Wheel Only	92749	2	18 x 38
1	Wheel & Tire Assembly	101500	2	TL23.1B26G 10-Ply R-3
	Wheel & Tire Assembly	14298	2	TL23.1B26G 10-Ply R-1
	Wheel Only	92413	2	20 x 26
1	Wheel & Tire Assembly	14300	2	TL24.5B32G 12-Ply R-3
	Wheel & Tire Assembly	107288	2	TL24.5B32G 12-Ply R-1
	Wheel Only	111128WO	2	21 x 32
1	Wheel & Tire Assembly	107620	2	TL30.5LB32G 14-Ply R-3
	Wheel & Tire Assembly	17468	2	TL30.5LB32G 14-Ply R-1
	Wheel Only	17377WO	2	27 x 32
2	Valve Stem	93300	2	
	Plug, Rim Hole	95365	2	5/8"
	Air-Liquid Spud Plug	96729	2	
	Valve Stem Spud	96730	2	5/8"

GRAIN CARTS — Parts

Model 1160 Wheels & Tires

Please visit www.unverferth.com/parts/ for the most current parts listing.

TIRES
 For questions regarding new tire warranty, please contact your local original equipment tire dealer. Used tires carry no warranty. Tire manufacturers' phone numbers and websites are listed in Maintenance Section for your convenience.

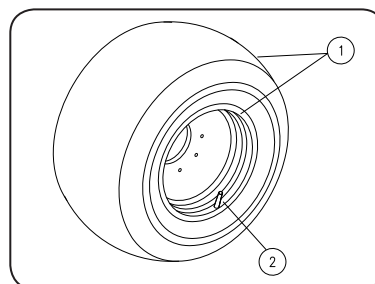

ITEM	DESCRIPTION	PART NO.	QTY.	NOTES
				10 Hole Wheels, 11.070" Pilot, 13.187" B.C.
1	Wheel & Tire Assembly	101427	2	TL24.5B32 12-Ply R-3 Diamond Tread
	Wheel & Tire Assembly	105071	2	TL24.5B32 12-Ply R-1 Tractor Tread
	Wheel Only	92416	2	21 x 32
1	Wheel & Tire Assembly	102107	2	TL30.5LB32 14-Ply R-3 Diamond Tread
	Wheel & Tire Assembly	107269	2	TL30.5LB32 14-Ply R-1 Tractor Tread
	Wheel Only	92417	2	27 x 32
2	Valve Stem	93300	2	
	Plug, Rim Hole	95365	2	5/8"
1	Wheel & Tire Assembly	15089	2	TL24.5X32 10-Ply (Minimum) R-1 Used
	Wheel Only	92416	2	21 x 32
	Tube	*	2	24.5 x 32
	Plug, 1 1/4"	92623	2	
1	Wheel & Tire Assembly	17741	2	TL520/85R38 R-1
	Wheel Only	17740W0	2	18 x 38

For proper tube sizes please contact your local tire dealer to access these.

GRAIN CARTS — Parts

Decals

Please visit www.unverferth.com/parts/ for the most current parts listing.

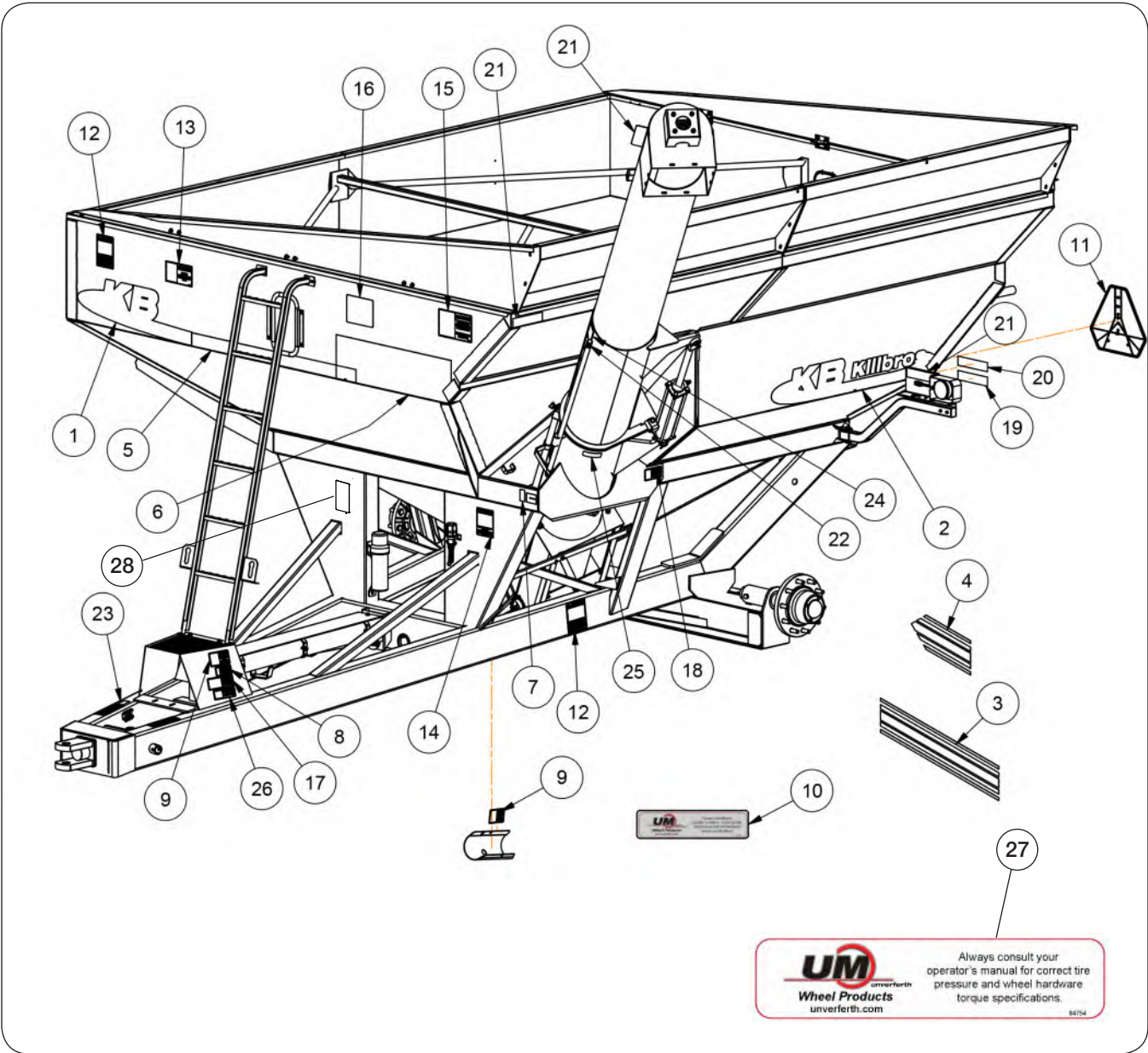

GRAIN CARTS — Parts

Decals

Please visit www.unverferth.com/parts/ for the most current parts listing.

ITEM	DESCRIPTION	PART NO.	QTY.	NOTES
1	Decal, Killbros	9005266	3	S/N D53710100 & Up (Model 1150) S/N D53700100 & Up (Model 1160)
		104420	4	S/N D53710099 & Prior (Model 1150) S/N D53700099 & Prior (Model 1160)
2	Decal, KB Killbros	9005292	1	S/N D53710100 & Up (Model 1150) S/N D53700100 & Up (Model 1160)
3	Decal, Stripe - 6 x 24"	104284	9	S/N D53710099 & Prior (Model 1150) S/N D53700099 & Prior (Model 1160)
4	Decal, Stripe - 6 x 12"	104286	8	S/N D53710099 & Prior (Model 1150) S/N D53700099 & Prior (Model 1160)
5	Decal, Stripe - 2 7/8 x 50"	9005267	4	S/N D53710100 & Up (Model 1150) S/N D53700100 & Up (Model 1160)
6	Decal, Model No. - 1150	902081	3	S/N D53710100 & Up (Model 1150) S/N D53700100 & Up (Model 1160)
		9003701	3	S/N D53710099 & Prior (Model 1150) S/N D53700099 & Prior (Model 1160)
	Decal, Model No. - 1160	902082	3	S/N D53710100 & Up (Model 1150) S/N D53700100 & Up (Model 1160)
		9003702	3	S/N D53710099 & Prior (Model 1150) S/N D53700099 & Prior (Model 1160)
7	Decal, FEMA	91605	1	
8	Decal, WARNING (Read & Understand)	97961	1	
9	Decal, DANGER (Driveshaft)	95046	3	
10	Decal, Wheel Systems	94754	2	
11	SMV Emblem	TA510514	1	
12	Decal, WARNING (Auger PTO)	9003475	3	
13	Decal, WARNING (No Riders)	9003476	1	
14	Decal, DANGER (Fust For Kids)	9003478	1	
15	Decal, DANGER (Electrical Lines)	9003474	1	
16	Decal, Important (Flow Control Gate)	9003477	1	
17	Decal, WARNING (Tongue Drop)	94094	1	
18	Decal, WARNING (Hydraulic Fluid)	95445	1	
19	Reflector "FLUORESCENT"	9003125	2	2 x 9"
20	Reflector "RED"	9003126	2	2 x 9"
21	Reflector "AMBER"	9003127	6	2 x 9"
22	Decal, Reflective Checker Tape	265384	1	
23	Decal, Shear-Bolt	9003574	1	
24	Decal, Flow Control	92563	1	
25	Decal, WARNING (Pinch Point)	95839	1	
26	Decal, CAUTION (Transport Chain)	97575	1	
27	Decal, UM Wheel Systems	94754	2	
28	Decal, IMPORTANT "PTO Engagement"	9008151	1	

GRAIN CARTS — Parts

Sideboards

Please visit www.unverferth.com/parts/ for the most current parts listing.

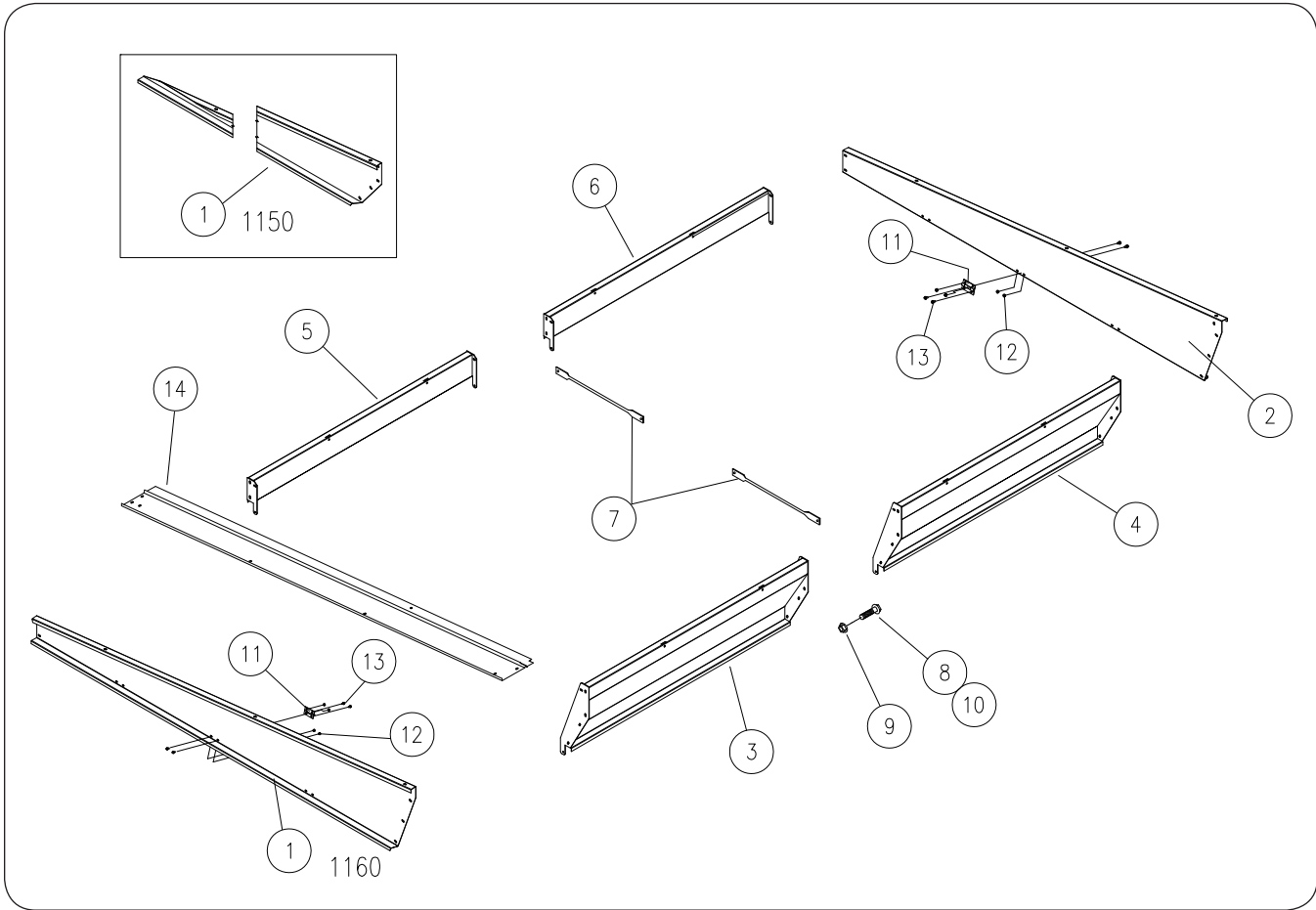

GRAIN CARTS — Parts

Sideboards

Please visit www.unverferth.com/parts/ for the most current parts listing.

ITEM	DESCRIPTION	PART NO.		QTY.	NOTES
		1150	1160		
1	Front Board	253240W	253252W	1	Model 1150 - 16" to 0"
	Hinge Front Board Kit*	253246	253250	-	Model 1160 - 23" to 7"
2	Rear Board	253241W	253243W	1	Model 1150 - 16" to 0"
	Hinge Rear Board Kit*	253247	253251	-	Model 1160 - 23" to 7"
3	Left-Front Side Board	253193W	253189W	1	Model 1150 - 16" Tall Model 1160 - 23" Tall
4	Left-Rear Side Board	253194W	253190W	1	Model 1150 - 16" Tall Model 1160 - 23" Tall
5	Right-Front Side Board	-	253122W	1	7" Tall
6	Right-Rear Side Board	-	253123W	1	7" Tall
7	Side Board Support	220032W	>	1 / 2	39 7/8" Long
8	Flange Screw, 3/8-16 UNC x 3/4	95585	>	12	
9	Flange Nut, 3/8-16 UNC	91263	>	14	
10	Flange Screw, 3/8-16 UNC x 1	91262	>	2	
11	Hinge	9004626	>	6	
12	Flange Nut, 5/16-18 UNC	91257	250431	24	
13	Flange Screw, 5/16-18 UNC x 3/4	91256		24	

GRAIN CARTS — Parts

Electrical

Please visit www.unverferth.com/parts/ for the most current parts listing.

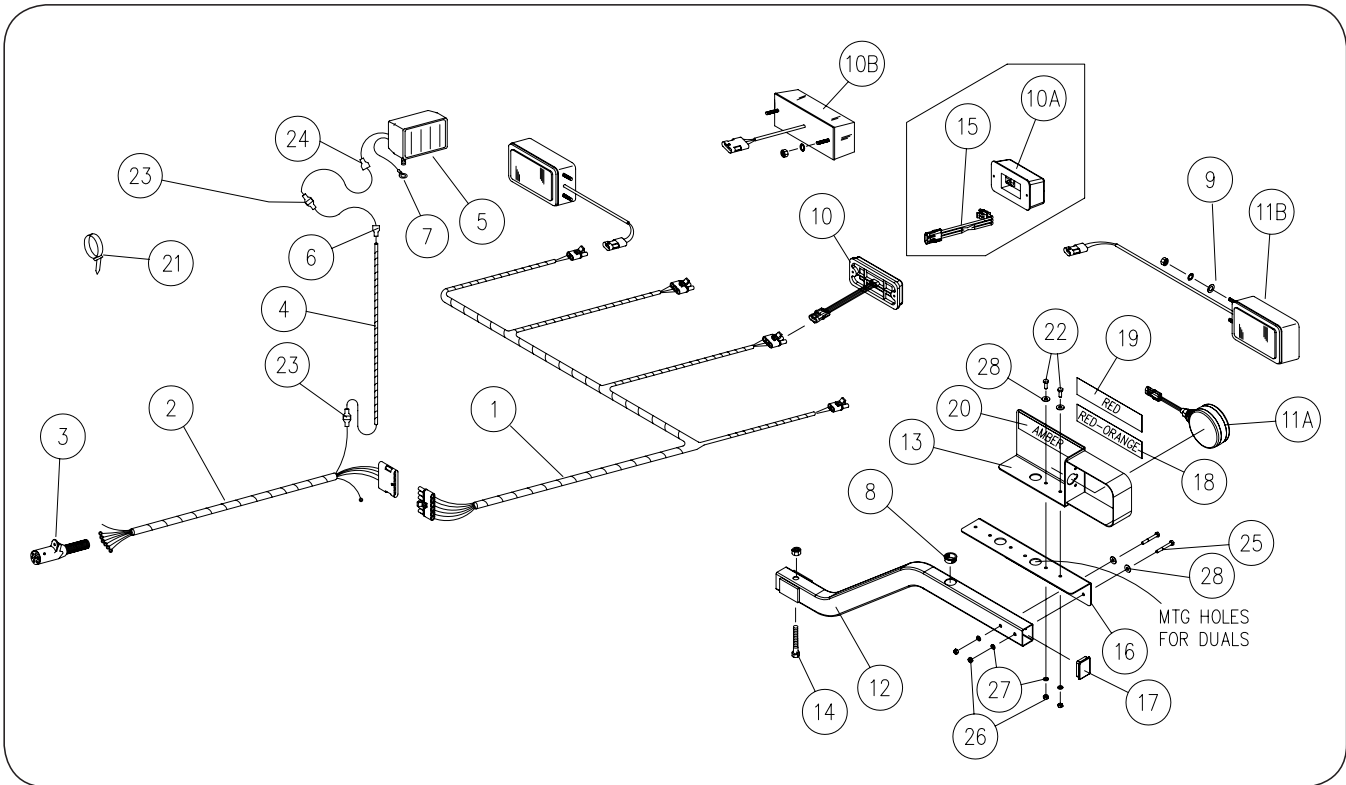

GRAIN CARTS — Parts

Electrical

Please visit www.unverferth.com/parts/ for the most current parts listing.

ITEMS	DESCRIPTION	PART NO.	QTY	NOTES
1	Wiring Harness, Rear	9003510	1	
2	Wiring Harness, Front	9003509	1	
3	Electrical Coupler	92450	1	
4	Wiring Harness, Auger	9004350	1	
5	LED Auger Light	9500807	1	
6	Connector, Male	9004140	1	
7	Connector 1/2" Eyelet	9002127	1	
8	Grommet	9001816	4	
9	Flat Washer 3/16	9405-052	4	
10	Red LED Light Kit	265642	1	
10A	Replacement Lens - Red	9003384	-	
10B	LED Light Replacement Kit	232170	-	Includes Wiring Harness
11A	Lamp - Amber w/LED Double-Face	9005142	2	
11B	Light, Amber - Turn/Flasher	9003048	2	
	Replacement Lens - Amber	9004017	-	
12	Light, Tube Weldment	251398B	2	
13	LH Light Bracket Weldment	252302B	1	
	RH Light Bracket Weldment	252301B	1	
14	Capscrew 1/2-13UNC x 3	9390-107	2	
	Locknut 1/2-13UNC	9003397	2	
15	Wiring Harness 10"	9005097	2	For LED Lights Only
16	LH Plate	251406B	1	
	RH Plate	251407B	1	
17	Tube Plug	9003515	2	
18	Reflector, Fluorescent "Red-Orange"	9003125	2	2x9"
19	Reflector, "Red"	9003126	2	2x9"
20	Reflector, "Amber"	9003127	2	2x9"
21	Cable Tie 6"	9000106	A/R	
	Cable Tie 15 1/2"	9000107	A/R	
22	Capscrew 1/4-20UNC x 3/4	9390-003	4	
23	Butt Connector	9000166	1	
24	Female Connector	TAB65407	1	
25	Capscrew 1/4-20UNC x 2	9390-009	4	
26	Hex Nut 1/4-20UNC	9394-002	8	
27	Lock Washer 1/4	9404-017	8	
28	Flat Washer 1/4	9405-064	8	

GRAIN CARTS — Parts

Auger & Hydraulics

Please visit www.unverferth.com/parts/ for the most current parts listing.

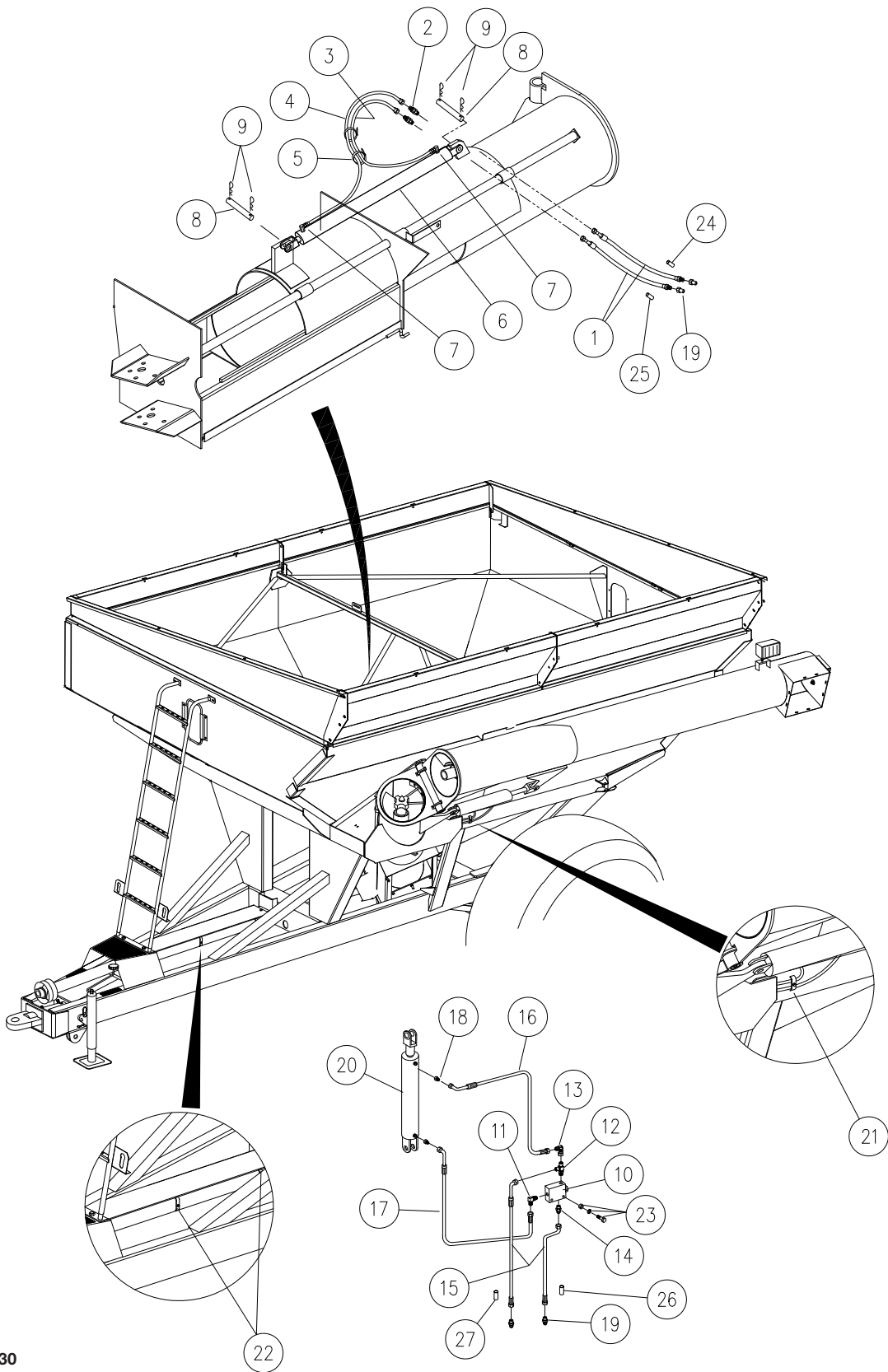

252930

GRAIN CARTS — Parts

Auger & Hydraulics

Please visit www.unverferth.com/parts/ for the most current parts listing.

ITEM	DESCRIPTION	PART NO.	QTY.	NOTES
1	Hydraulic Hose, 1/4 Dia. x 228	9002215	2	
2	Bulkhead Union	95192	2	9/16-18JIC Male x 9/16-18 JIC Bulkhead Thrd w/Nut
3	Hydraulic Hose, 1/4" Dia. x 42	93847	1	
4	Hydraulic Hose, 1/4" Dia. x 24	95002	1	4000 PSI
5	Cable Tie, 6"	9000106	5	
	Cable Tie, 15 1/2"	9000107	2	
6	Hydraulic Cylinder, Flow Control	Page 5-23	1	
7	Elbow 90°	9874	2	9/16-18 JIC Male x 3/4-16 O-Ring Adj Male
8	Clevis Pin, 1" Dia. x 2 7/8	233760	2	
9	Hairpin Cotter .177" Dia. x 3.68	92424	4	
10	Pilot Operated Check Valve	9003990	1	RD-1650
11	Elbow, 90	97445	1	
12	Tee, Straight Run	9004064	2	
13	Elbow, 9/16-18 JIC M-F Swivel	9876	1	
14	Adapter	9001495	1	
15	Hydraulic Hose 1/4 x 228	9002215	2	3000 PSI
16	Hydraulic Hose 1/4 x 106	9003563	1	3000 PSI
17	Hydraulic Hose 1/4 x 95	9002873	1	4000 PSI
18	Adapter w/ 0.055 Restrictor	91608	2	9/16-18 JIC Male x 3/4-16 O-Ring Male
19	Male Tip Coupling	91383	4	3/4-16 O-Ring Female Threaded 3000 PSI
20	Hydraulic Cylinder, Auger	Page 5-23	1	
21	Hose Bracket, 3"	807382B	4	
22	Hose Bracket, 4"	7-0043B	2	
23	Capscrew, 5/16-18 UNC x 2	9390-034	2	
	Lockwasher, 5/16	9404-019	2	
	Hex Nut, 5/16-18 UNC	9394-004	2	

Upper Auger

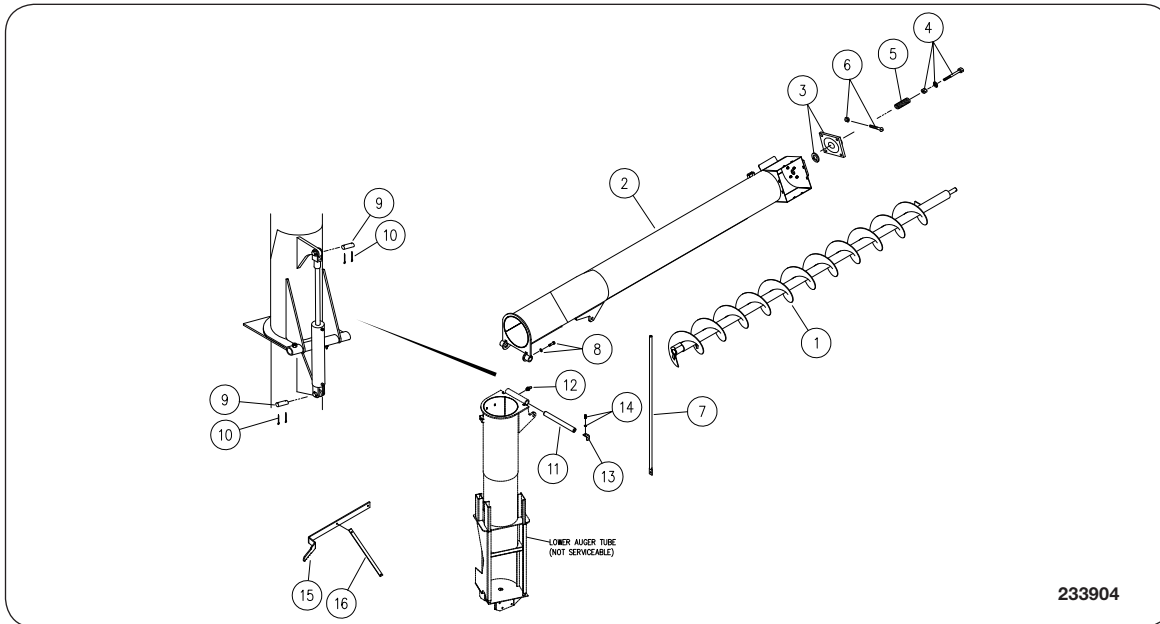

233904

ITEM	DESCRIPTION	PART NO.	QTY.	NOTES
1	Upper Auger	253016B	1	
2	Upper Tube Housing =Green=	253113G	1	
	Upper Tube Housing =Red=	253113R	1	
3	Flange Bearing, 1 1/2 4-Hole	92406	1	
	Washer	9001197	AR	2x1.554x.134
4	Capscrew, 1/2-13 UNC x 5 1/2	9390-114	4	
	Flatwasher, 1/2	9405-094	4	
	Locknut, 1/2-13 UNC Hex	94981	4	
5	Auger Spring, 1x4	9001812	4	
6	Machine Screw, 5/16-18 UNC x 2	95572	1	
	Nut, 5/16-18 UNC	9394-004	1	
7	Indicator Rod	250765B	1	
8	Capscrew, 1/2-13 UNC x 1 1/4	9390-100	1	
	Locknut, 1/2-13 UNC	94981	1	
9	Cylinder Pin	804572	2	1 x 3 1/2"
10	Cotter Pin, 3/16 x 2	9391-046	4	
11	Pivot Shaft, Auger	253074	1	
12	Grease Zerk, 1/4	91160	1	
13	Keeper	233649	1	
14	Capscrew, 1/2-13 UNC x 1 1/4	9390-100	1	
	Lockwasher, 1/2	9404-025	1	
15	Door Slide Handle	253100B	1	
16	Door Lift	253099B	1	

Lower Auger & Driveline

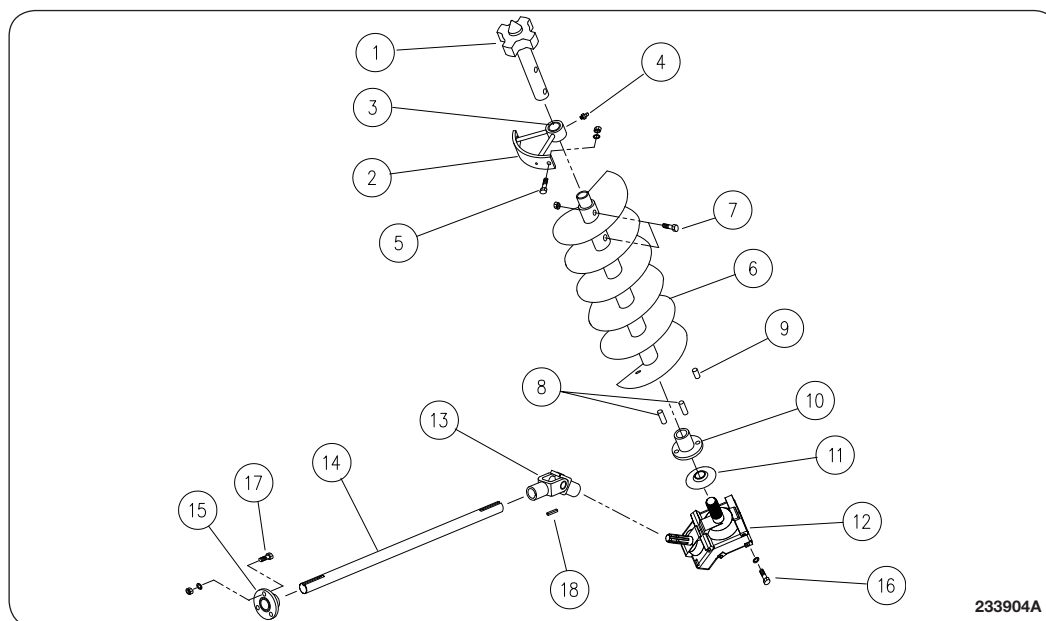

233904A

ITEM	DESCRIPTION	PART NO.	QTY.	NOTES
1	Drive Dog/Misile Shaft (4 Tooth)	250424	1	
2	Hanger Bushing Assembly	250119B	1	Includes Item #4
3	Bushing, Bronze, 2" I.D.	95315	1	
4	Zerk 90°, 1/4-28	9000875	1	
5	Capscrew, 3/8-16 UNC x 1 1/4	9390-056	3	
	Lock Washer, 3/8	9404-021	3	
	Hex Nut, 3/8-16 UNC	9394-006	3	
6	Lower Auger	253015-SER	1	
7	Capscrew, 1/2-13 UNC x 4	9390-111	2	
	Locknut, 1/2-13 UNC	94981	2	
8	Lower Drive Dog	250005	2	1 x 4"
9	Auger Height Pin	250004	1	1 x 2"
10	Lower Drive Bushing	290017B	1	
11	Not Applicable	-	-	
12	50° Gearbox	TAB45504	1	See Page 5-26
13	U-Joint	95253	1	See Page 5-27
14	Driveshaft	253164	1	102 3/4" Long
15	Flangette Bearing, 1 1/4"	92658	2	
16	Capscrew, 1/2-13 UNC x 1 1/4	9390-100	8	
	Lock Washer, 1/2	9404-025	8	
	Capscrew, 3/8-16 UNC x 1	9390-055	6	
17	Lock Washer, 3/8	9404-021	6	
	Hex Nut, 3/8-16 UNC	9394-006	6	
	Key, 5/16 x 2	95176	1	

GRAIN CARTS — Parts

Directional Downspout Control Kit #27122B (Optional)

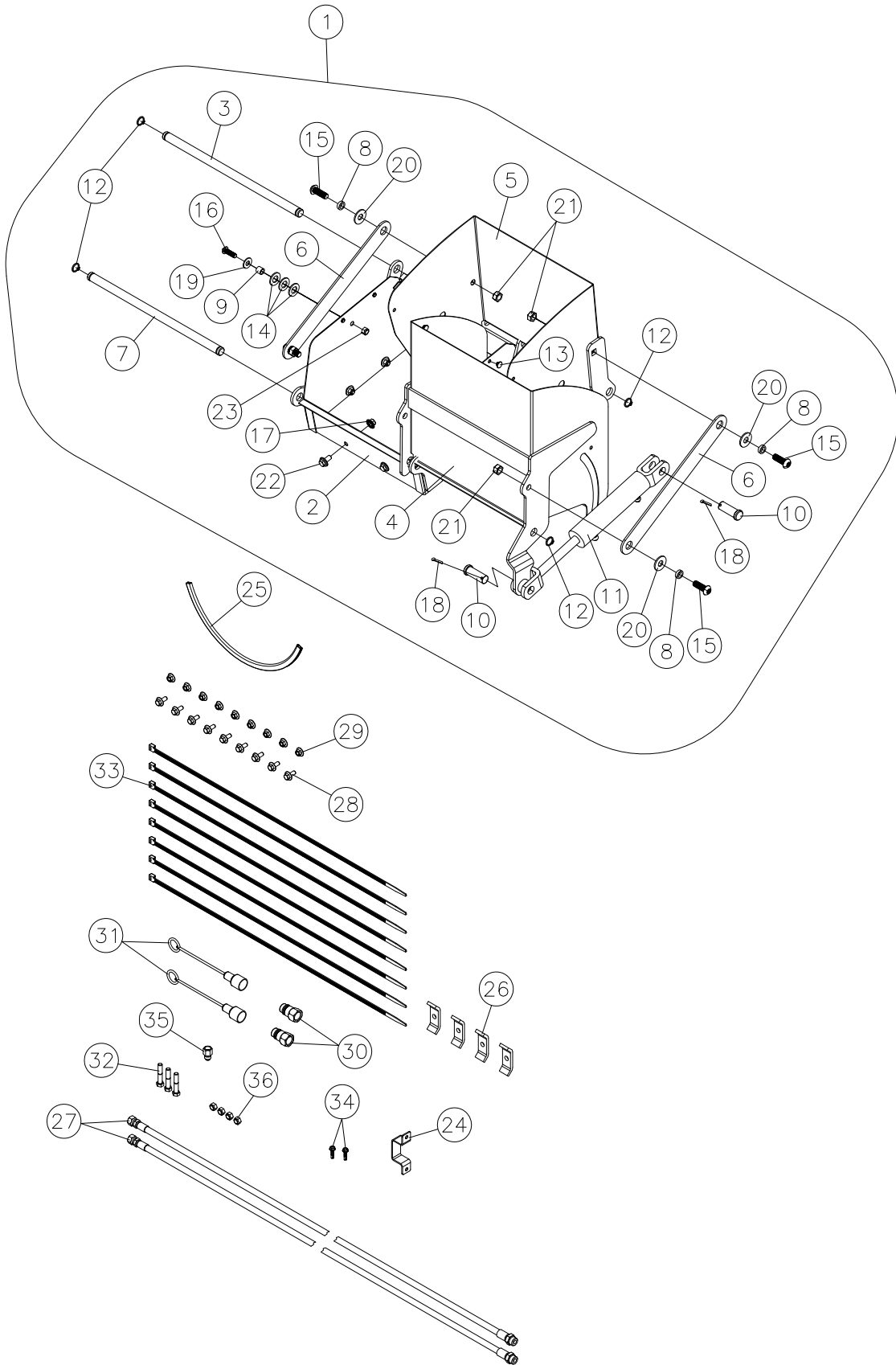

GRAIN CARTS — Parts

Directional Downspout Control Kit #27122B (Optional)

ITEM	PART NO.	DESCRIPTION	QTY	NOTES
1	27121B	14" Hydraulic Directional Spout =Black=	1	
2	27092B	14" Hood Weldment =Black=	1	
3	27095	Bar, 3/4D x 16 7/8 Lg.	1	
4	27103B	Chute Weldment =Black=	1	
5	27105B	Chute Weldment =Black=	1	
6	27114	Arm Link Plate	2	
7	27120	Bar, 3/4D x 16 3/8 Lg.	1	
8	281369	Bushing, 3/4D x .219	4	
9	281372	Bushing, 9/16D x 1/2	2	
10	9002032	Clevis Pin	2	
11	9003789	Hydraulic Cylinder, 1 1/2 x 4 (3000 PSI)	1	
12	9003810	Snap Ring	4	
13	9004457	Plug, Plastic	8	
14	9004494	Washer	6	
15	902337	Socket Capscrew, 1/2-13 x 1 1/2	4	
16	902338	Socket Capscrew, 3/8-16 x 1 1/4	2	
17	91263	Large Flange Nut, 3/8-16UNC	8	
18	9391-034	Cotter Pin	2	
19	9405-076	Flat Washer, 3/8	2	
20	9405-088	Flat Washer, 1/2	4	
21	94981	Locknut, 1/2-13UNC	4	
22	95585	Large Flange Capscrew, 3/8-16 x 3/4 Gr.5	8	
23	9928	Locknut, 3/8-16UNC Gr.5	2	
24	24389B	Bracket =Black=	1	
25	27131	Trim Lock, 17 3/8" Lg.	1	
26	807382B	Hose Clamp Plate =Black=	4	
27	9004637	Hose, 1/4 x 430 (3000 PSI)	2	
28	91256	Large Flange Screw, 5/16-18 x 3/4 Gr.5	9	
29	91257	Large Flange Hex Nut, 5/16-18 Gr.5	9	
30	91383	Male Tip Coupling, 3/4-16	2	
31	91511	Dust Cap	2	
32	9390-059	Capscrew, 3/8-16UNC x 2 Gr.5	3	
33	94038	Cable Tie, 32" Lg.	8	
34	9512	Self-Drill Screw, 1/4-14 x 1	2	
35	95193	Adapter, 9/16-18 JIC FM x 9/16-18 JIC M	1	
36	9928	Locknut, 3/8-16UNC Gr.5	4	

Auger Chutes

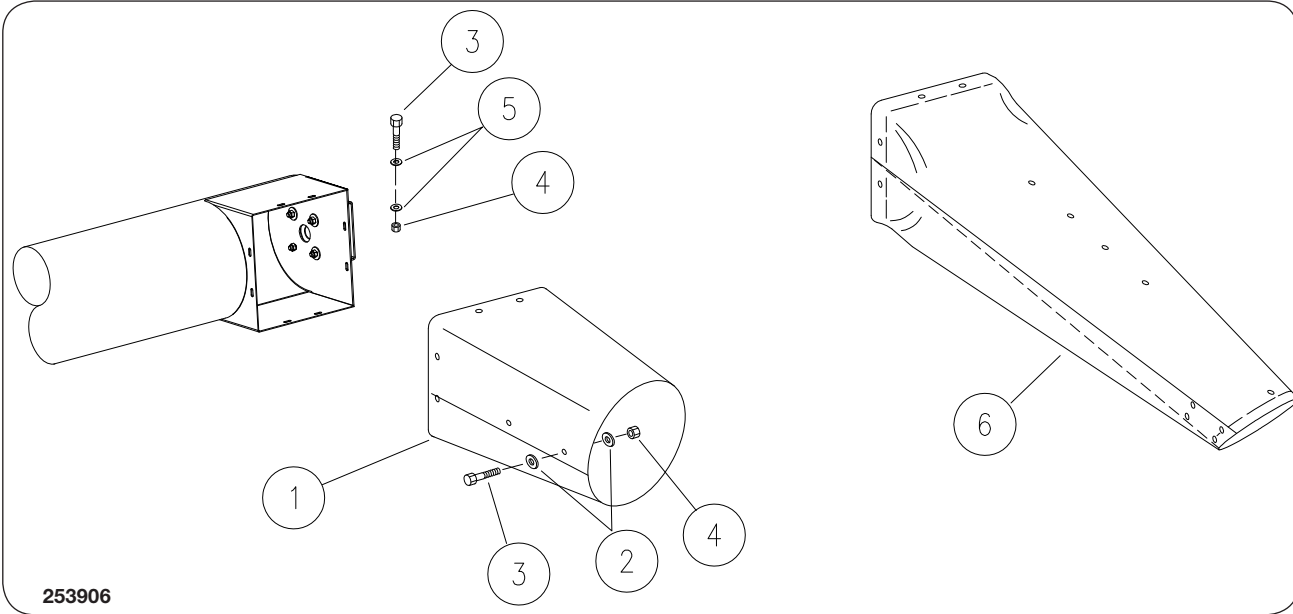

ITEM	DESCRIPTION	PART NO.	QTY.	NOTES
	Chute Kit	253006	1	Includes Items 1 thru 4
1	Chute	9001437	1	
2	Fender Washer, 2" OD	94763	6	
3	Capscrew, 1/4-20 UNC x 1	9390-005	11	
4	Locknut, 1/4-20 UNC	9936	11	
5	Fender Washer, 1" OD	9405-066	8	
6	Adjustable Extended Length Chute	252047	1	Option

GRAIN CARTS — Parts

Auger Cylinder 3" x 20"

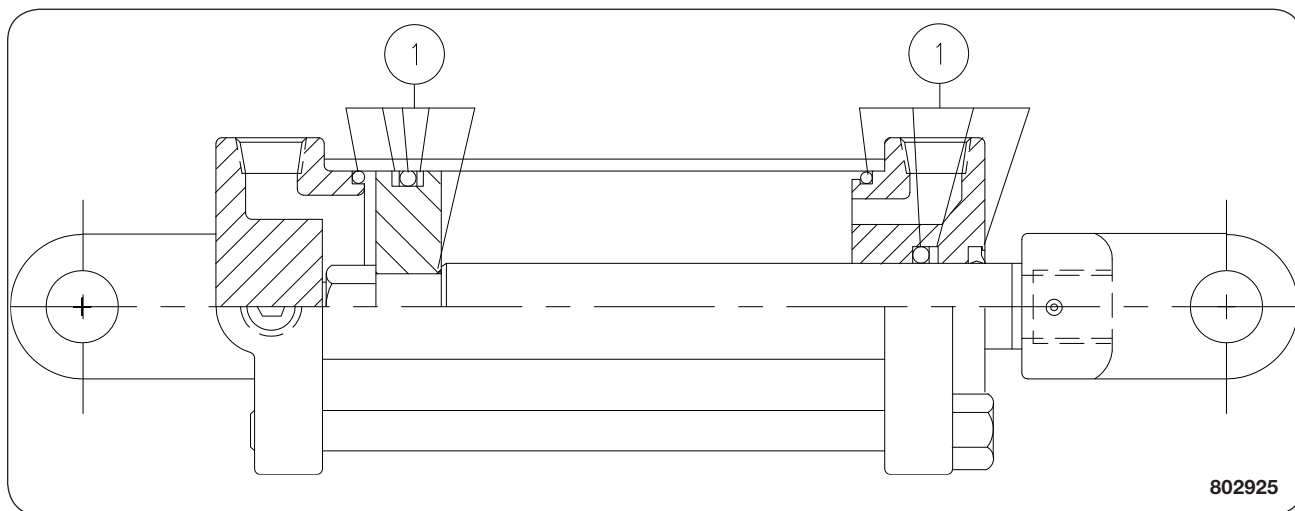

ITEM	DESCRIPTION	PART NO.	QTY	NOTES
	Cylinder Complete	9003103	1	
1	Seal Kit	9003772	1	

Flow Control Cylinder 2 1/2" x 36"

ITEM	DESCRIPTION	PART NO.	QTY	NOTES
	Cylinder Complete	9005363	1	
1	Seal Kit	9005409	1	

GRAIN CARTS — Parts

PTO Assembly

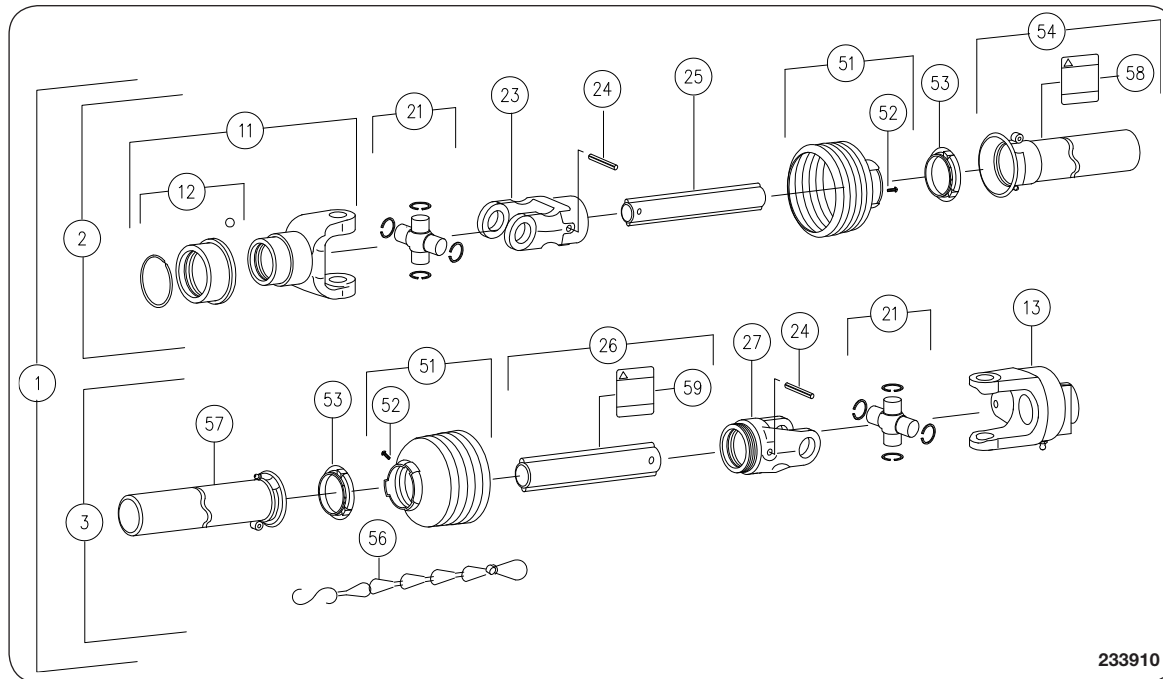

233910

ITEM	DESCRIPTION	PART NO.	QTY.	NOTES
1	PTO Shaft w/Shielding	95271	1	1 3/8-21 Spline
	PTO Shaft w/Shielding	9002662	1	1 3/4-20 Spline
2	Front Half PTO	95269	1	1 3/8-21 Spline
	Front Half PTO	9002663	1	1 3/4-20 Spline
3	Rear Half PTO	95270	1	1 1/4 Rd 5/16 Kw
11	End Yoke	92361	1	1 3/8-21 Spline
	End Yoke	92379	1	1 3/4-20 Spline
12	Quick Disconnect Kit	95217	1	1 3/8-21 Spline
	Quick Disconnect Kit	93856	1	1 3/4-20 Spline
13	Shear Bolt Clutch	95254	1	1 1/4 Rd 5/16 Kw
21	Cross & Bearing Kit	92364	2	
23	Front Inboard Yoke	95260	1	
24	Spring Pin	95268	2	
25	Inner Profile	95262	1	
26	Outer Profile	95263	1	
27	Rear Inboard Yoke	95261	1	
51	Shield Cone	95264	2	
52	Screw	92372	2	
53	Bearing Ring	95267	2	
54	Outer Shield	95265	1	
56	Safety Chain	92374	1	
57	Inner Shield	95266	1	
58	Danger Decal - Shield	92377	1	
59	Danger Decal - Steel	92378	1	

PTO Clutch

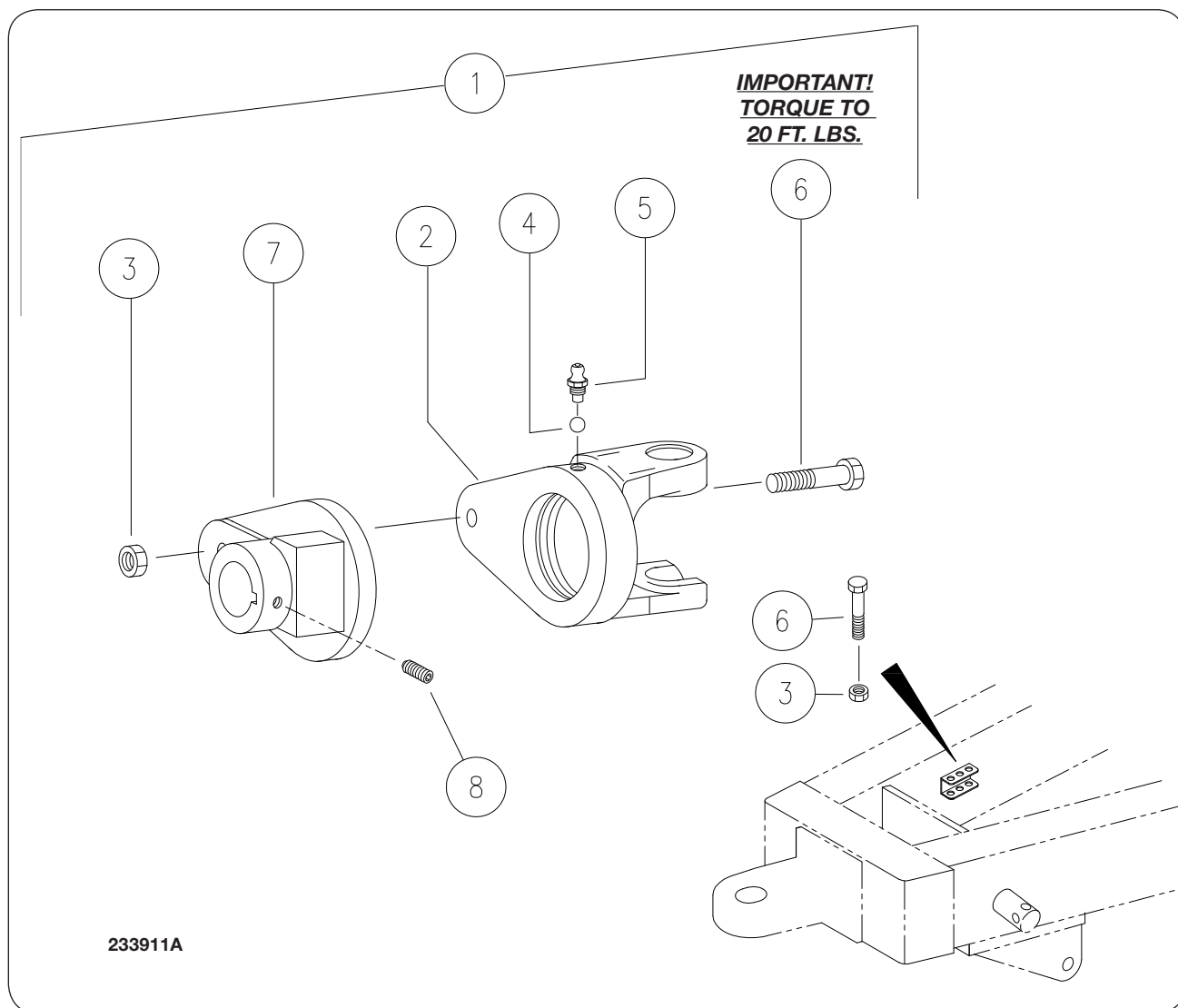

ITEM	DESCRIPTION	PART NO.	QTY.	NOTES
1	Complete Clutch	95254	1	
2	Shear Yoke	95255	1	
3	Locknut	95259	1	
4	Ball	95257	24	
5	Grease Zerk	95256	1	
6	Bolt, M8 x 50 DIN 931 8.8	94916-040	1	See Note *
7	Hub, 1 1/4 Rd w/5/16 Kw	95258	1	
8	Setscrew, 3/8-16 UNC x 1/2	9399-086	2	

*** IMPORTANT: USE GENUINE OEM REPLACEMENT PART.** Incorrect part may cause shear function to occur *too soon* causing inconvenience or *too late* resulting in damage to driveline and auger components. Tighten to specified torque value.

GRAIN CARTS — Parts

50° Gearbox

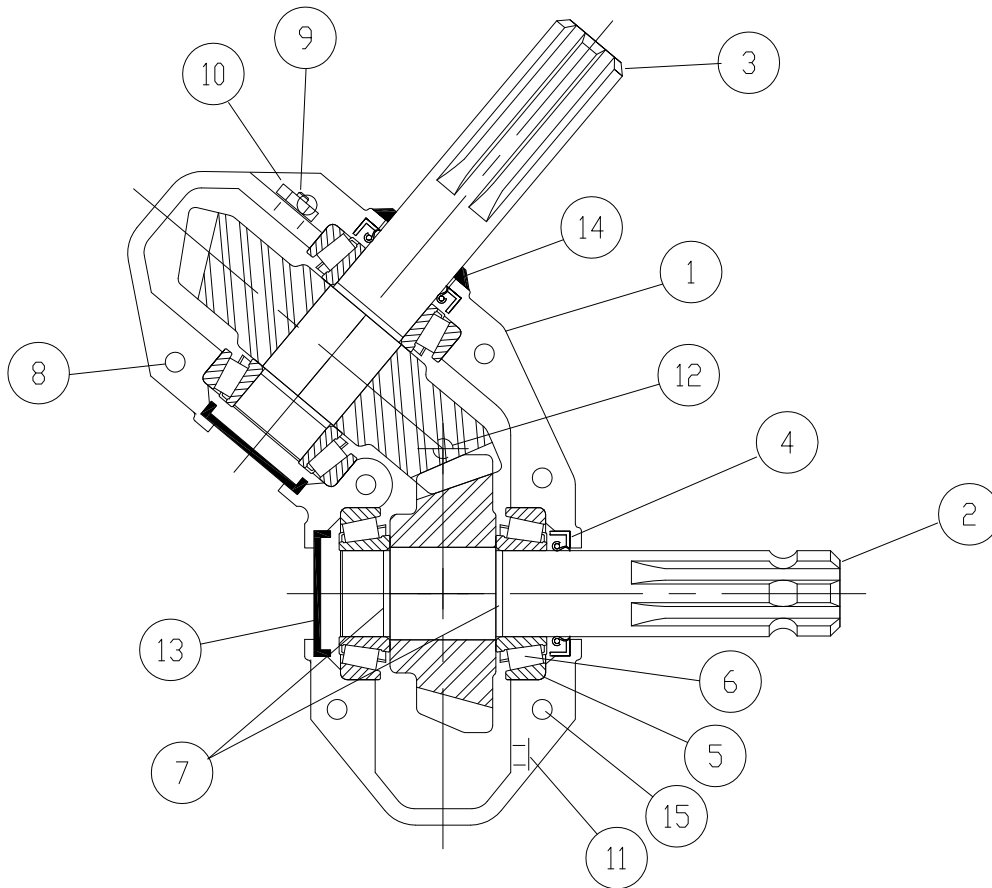

TAB45504

ITEM	DESCRIPTION	PART NO.	QTY.	NOTES
	Gearbox, Complete	TAB45504	1	Includes Items 1 thru 14
	1.6:1 Ratio			
1	Cast Half W/Thru Holes	9003451	1	
	Cast Half W/Threaded Holes	9003450	1	
2	Pinion Shaft (input)	TAH2394	1	1 3/8 - 6 Spline
3	Cross Shaft (Output)	TAH2396	1	1 3/8 - 6 Spline
4	Seal	92688	2	
5	Bearing Cup	92687	4	
6	Bearing Cone	92686	4	
7	Retaining Ring	92689	4	
8	Capscrew, 3/8-16 UNC x 2 1/4	95281	7	Socket Head
9	Plug, Pressure Relief	92352	1	
10	Hex Reducer Bushing	9003453	1	
11	Plug, 1/2" Pipe	95283	1	
12	Plug, 1/4" Pipe	92350	2	
13	End Cap	TA400301	2	
14	Seal, Gamma	TA50RB35	1	Output Shaft
15	Capscrew, 3/8-16 UNC x 1 1/2	9390-057	2	

Driveline U-Joint Assembly

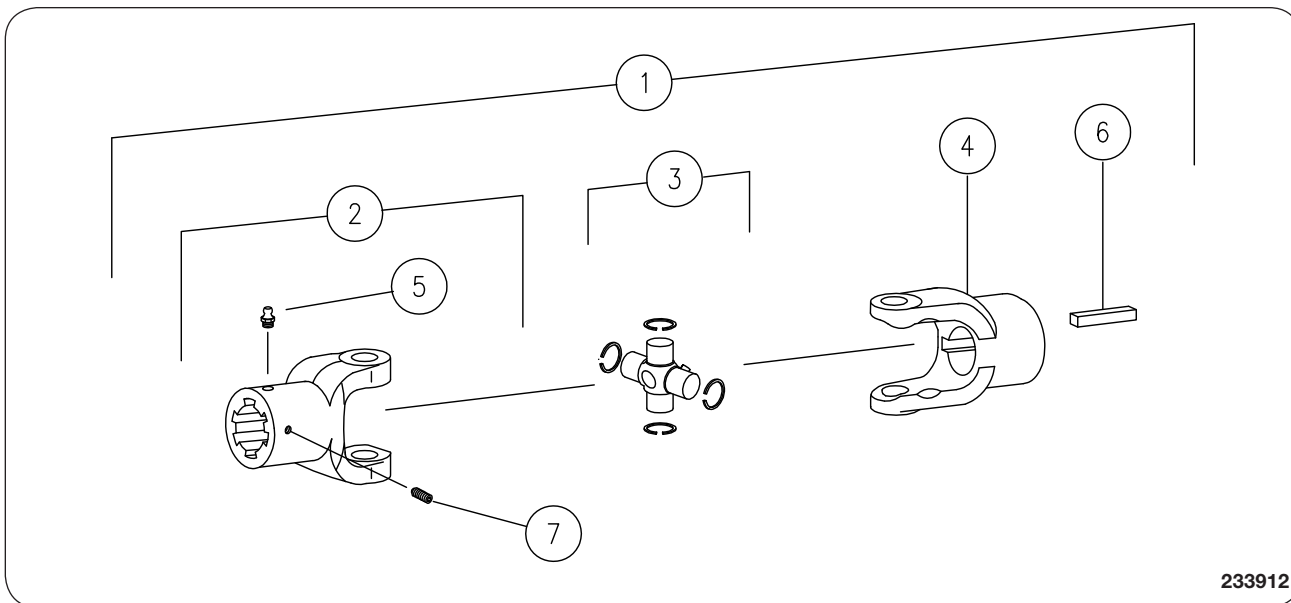

233912

ITEM	DESCRIPTION	PART NO.	QTY.	NOTES
1	U-Joint Assembly, Complete	95253	1	
2	Yoke, 1 3/8-6 Spline	95250	1	
3	Cross & Bearing Kit	92364	1	
4	Yoke, 1 1/4 Round with 5/16 Keyway	95251	1	
5	Grease Zerk	95252	1	
6	Key, 5/16 x 2	95176	1	
7	Set Screw 3/8-16UNC x 1/2	9399-086	2	Cup Point/Hex Socket



Unverferth[®]
Manufacturing Company, Inc.

www.unverferth.com